

Reference Manual

DOC. REV. 8/24/2011

VL-EPMs-M1

SUMIT-104 USB and SATA
Module with Optional PCIe Mini
Card or mSATA Socket





WWW.VERSALOGIC.COM

4211 West 11th Ave.
Eugene, OR 97402
(541) 485-8575
Fax (541) 485-5712

Copyright © 2011 VersaLogic Corp. All rights reserved.

Notice:

Although every effort has been made to ensure this document is error-free, VersaLogic makes no representations or warranties with respect to this product and specifically disclaims any implied warranties of merchantability or fitness for any particular purpose.

VersaLogic reserves the right to revise this product and associated documentation at any time without obligation to notify anyone of such changes.

PC/104 and the PC/104 logo are trademarks of the PC/104 Consortium. SUMIT, ISM, SUMIT-ISM, and the SUMIT logo are trademarks of the Small Form Factor Special Interest Group (SFF-SIG). All other product names and trademarks, registered trademarks, or service marks are property of their respective owners.

Product Release Notes

Rev 1.00 – Commercial Release.

Support Page

The VL-EPMs-M1 support page, at <http://www.versalogic.com/private/epmsm1support.asp>, contains additional information and resources for this product including:

- Reference Manual (PDF format)
- Device drivers
- Datasheets and manufacturers' links for chips used in this product
- Photograph of the circuit board

This is a private page for VL-EPMs-M1 users that can be accessed only by entering this URL address directly. It cannot be reached from the VersaLogic public website.

The VersaTech KnowledgeBase is an invaluable resource for resolving technical issues with your VersaLogic product.

[VersaTech KnowledgeBase](#)

Contents

Introduction	1
Features	1
Technical Specifications	2
RoHS-Compliance	3
About RoHS.....	3
Warnings.....	3
Electrostatic Discharge	3
Technical Support.....	4
Repair Service.....	4
Physical Description	5
Dimensions and Mounting.....	5
Hardware Assembly.....	7
External Connectors.....	8
VL-EPMs-M1 Connectors.....	8
VL-EPMs-M1 Connector Functions and Interface Cables	9
Operation	10
USB Ports	10
SATA Ports.....	10
Configuring a SATA RAID Set.....	11
PC/104 (ISA) Connector.....	11
PCIe Mini Card / mSATA Socket	12
SUMIT-A Bottom Connector	14
SUMIT-A Top Connector.....	15
SUMIT-B Top Connector	16
SUMIT-B Bottom Connector	17
Appendix A – References	18

Features

The VL-EPMs-M1 is an embedded SATA and USB interface module with an optional Mini PCIe or mSATA socket. Based on the SUMIT-ISM form factor, the VL-EPMs-M1 supports SUMIT and PC/104 (ISA) stackable expansion buses on a 90 mm x 96 mm (3.55" x 3.78") footprint. Configurations and feature sets include:

<i>Model</i>	<i>USB Ports</i>	<i>SATA Ports</i>	<i>Mini PCIe / mSATA Socket</i>	<i>Stackable Bus</i>
VL-EPMs-M1A	2 Type A 2 Pin-header	2	No	—
VL-EPMs-M1B	1 Type A 2 Pin-header	2	PCIe Mini Card	SUMIT-AB (Top and Bottom), ISA (Pass-through)
VL-EPMs-M1C	2 Type A 2 Pin-header	1	mSATA	—

All boards include the following features:

- Transient Voltage Suppression (TVS) devices on I/O interfaces for protection against power spikes and surges
- Designed to provide -40° to +85°C operation for reliable use in harsh environments
- Full compliance with EU Directive 2002/95/EC (RoHS) for devices used in Europe
- SUMIT-ISM (Legacy Type 1) form factor

The VL-EPMs-M1 features high-reliability design and construction. All VL-EPMs-M1 boards are subjected to functional testing and are backed by a limited two-year warranty. Careful parts sourcing and US-based technical support ensure the highest possible quality, reliability, service, and product longevity for this exceptional board.

Technical Specifications

Board Size:

PC/104™ standard:
90 mm x 96 mm (3.55" x 3.78")

Power Requirements:

+5V
3.5W typical (without PCIe wireless card)
15.9W max. (without PCIe wireless card)
16.5W (with PCIe wireless card in use)

Stackable Bus:

SUMIT: SUMIT-A, SUMIT-B*
PC/104*: ISA (pass-through only)

Operating Temperature:

-40° to +85°C

Storage Temperature:

-40° to +85°C

Airflow Requirements:

Free air from -40° to +85°C

USB:

Four USB 2.0 ports
USB 0-1 – Type A
USB 2-3 – 10-pin header

SATA:

One or two SATA 3 Gb/s ports

BIOS Compatibility

BIOS must support Plug and Play (PnP) and shadowing of option ROMs.

SATA RAID Driver/OS Compatibility:

Windows XP – Compatible
Windows 7, 32-bit – Compatible
Windows 7, 64-bit – Compatible (Windows forces use of 32-bit driver)
Linux – See KnowledgeBase article [VT1689](#)

Storage/Interface Socket:

One optional PCIe Mini Card (Model B) or one mSATA (Model C) socket

Weight:

VL-EPMs-M1A – 0.087 lb (0.039 kg)
VL-EPMs-M1B – 0.157 lb (0.071 kg)
VL-EPMs-M1C – 0.105 lb (0.047 kg)

* *Optional*

SUMIT Resources		
Form Factor: SUMIT-ISM (Legacy Type 1)		
	SUMIT A	SUMIT B*
PCIe x1	1	1
PCIe x4		–
USB	4	
ExpressCard	–	
LPC	–	
SPI / μ Wire	–	
SMBus / I ² C	SMBus	
+12V	–	
+5V	✓	✓
+5V _{sb}	–	–
+3.3V	–	–
SUMIT-A Bottom only on VL-EPMs-M1A. SUMIT-AB Top and Bottom on VL-EPMs-M1B. SMBus on VL-EPMs-M1B only.		

Data represents standard operation at +25°C with +5V supply unless otherwise noted. Specifications are subject to change without notification.

RoHS-Compliance

The VL-EPMs-M1 is RoHS compliant.

ABOUT ROHS

In 2003, the European Union issued Directive 2002/95/EC regarding the Restriction of the use of certain Hazardous Substances (RoHS) in electrical and electronic equipment.

The RoHS directive requires producers of electrical and electronic equipment to reduce to acceptable levels the presence of six environmentally sensitive substances: lead, mercury, cadmium, hexavalent chromium, and the presence of polybrominated biphenyls (PBB) and polybrominated diphenyl ethers (PBDE) flame retardants, in certain electrical and electronic products sold in the European Union (EU) beginning July 1, 2006.

VersaLogic Corp. is committed to supporting customers with high-quality products and services meeting the European Union's RoHS directive.

Warnings

ELECTROSTATIC DISCHARGE

Electrostatic discharge (ESD) can damage boards, disk drives, and other components. The circuit board must only be handled at an ESD protective workstation. If an approved station is not available, some measure of protection can be provided by wearing a grounded antistatic wrist strap. Keep all plastic away from the board. Do not slide the board over any surface.

After removing the board from its protective wrapper, place the board on a grounded, static-free surface, component side up. Use an antistatic foam pad if available.

The board should always be protected inside a closed metallic antistatic envelope during shipment or storage.

Technical Support

If you are unable to solve a problem after reading this manual, please visit the VL-EPMs-M1 product support web page (see below). The support page provides links to component datasheets and device drivers.

[VL-EPMs-M1 Support Page](http://www.versalogic.com/private/epmsm1support.asp)

<http://www.versalogic.com/private/epmsm1support.asp>

The VersaTech KnowledgeBase contains a wealth of technical information about VersaLogic products, along with product advisories. Click the link below to see all KnowledgeBase articles related to the VL-EPMs-M1.

[VersaTech KnowledgeBase](#)

If you have further questions, contact VersaLogic Technical Support at (541) 485-8575. VersaLogic support engineers are also available via e-mail at Support@VersaLogic.com.

REPAIR SERVICE

If your product requires service, you must obtain a Returned Material Authorization (RMA) number by calling (541) 485-8575.

Please provide the following information:

- Your name, the name of your company, your phone number, and your e-mail address
- The name of a technical contact if any questions arise
- Quantity of items being returned
- The model and serial number (barcode) of each item
- A detailed description of the problem
- Steps you have taken to resolve or recreate the problem
- The return shipping address

Warranty Repair

All parts and labor charges are covered, including return shipping charges for UPS Ground delivery to United States addresses.

Non-warranty Repair

All non-warranty repairs are subject to diagnosis and labor charges, parts charges, and return shipping fees. Please specify the shipping method you prefer and provide a purchase order number for invoicing the repair.

Note

Please mark the RMA number clearly on the outside of the box before returning. Failure to do so can delay the processing of your return.

Dimensions and Mounting

The VL-EPMs-M1 complies with the SUMIT-ISM (Legacy Type 1) form factor specification, which provides for specific mounting hole and stackable bus locations as shown in the diagram below.

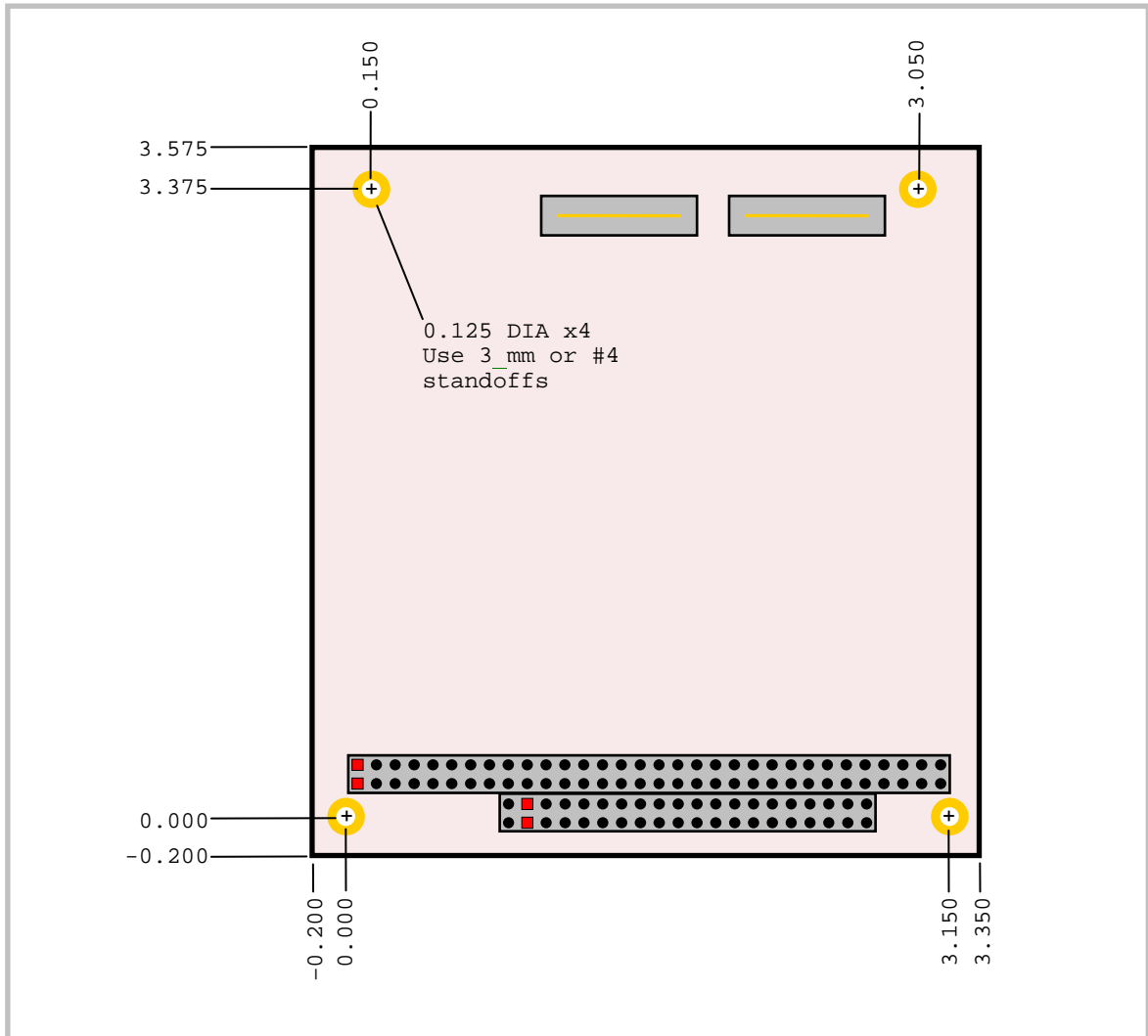

Figure 1. VL-EPMs-M1 Dimensions and Mounting Holes
(Not to scale. All dimensions in inches.)

Caution The board must be supported at all four mounting points to prevent excessive flexing when expansion modules are mated and detached. Flex damage caused by excessive force on an improperly mounted circuit board is not covered under the product warranty.

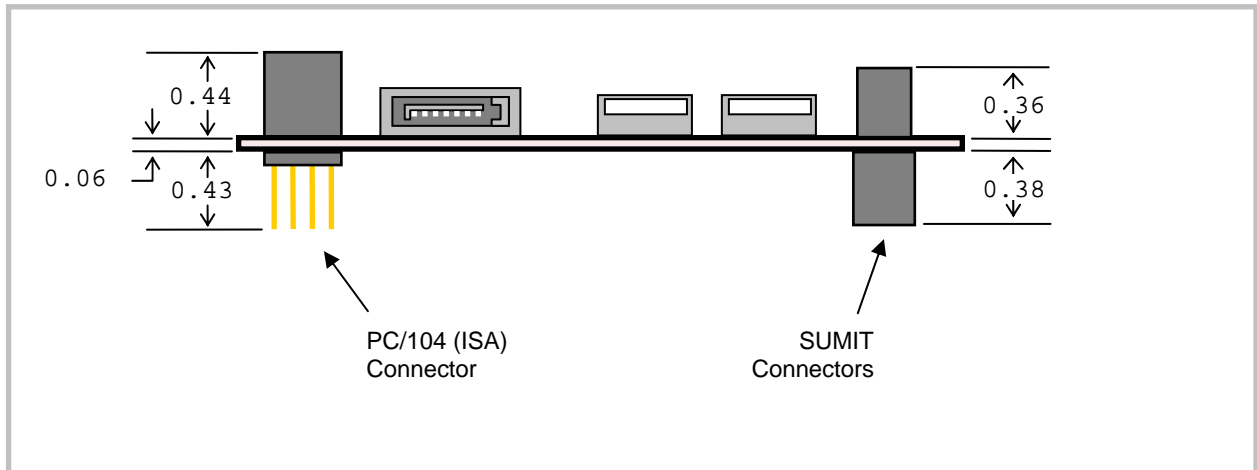

Figure 2. VL-EPMs-M1B Height Dimensions
(Not to scale. All dimensions in inches.)

HARDWARE ASSEMBLY

The VL-EPMs-M1 comes in configurations that use SUMIT-A only, or SUMIT-AB and PC/104 (ISA) connectors. The VL-EPMs-M1B can be added to the middle or top of the stack, above any SUMIT boards and below any PC/104 boards. The VL-EPMs-M1A and C can be added only to the top of the stack.

The entire assembly can sit on a table top or be secured to a base plate. When bolting the unit down, make sure to secure all four standoffs to the mounting surface to prevent circuit board flexing. Standoffs are secured to the top circuit board using four pan head screws. Standoffs and screws are available (VL-HDW-105/VL-HDW-106). Note that the standoffs in this kit are 15.24 mm (0.6") and must not be mixed with 15 mm (0.59") standoffs (VL-HDW-100/VL-HDW-101).

An extractor tool is available (part number VL-HDW-201) to separate modules from the stack. Use caution when using the extractor tool so as not to damage any board components.

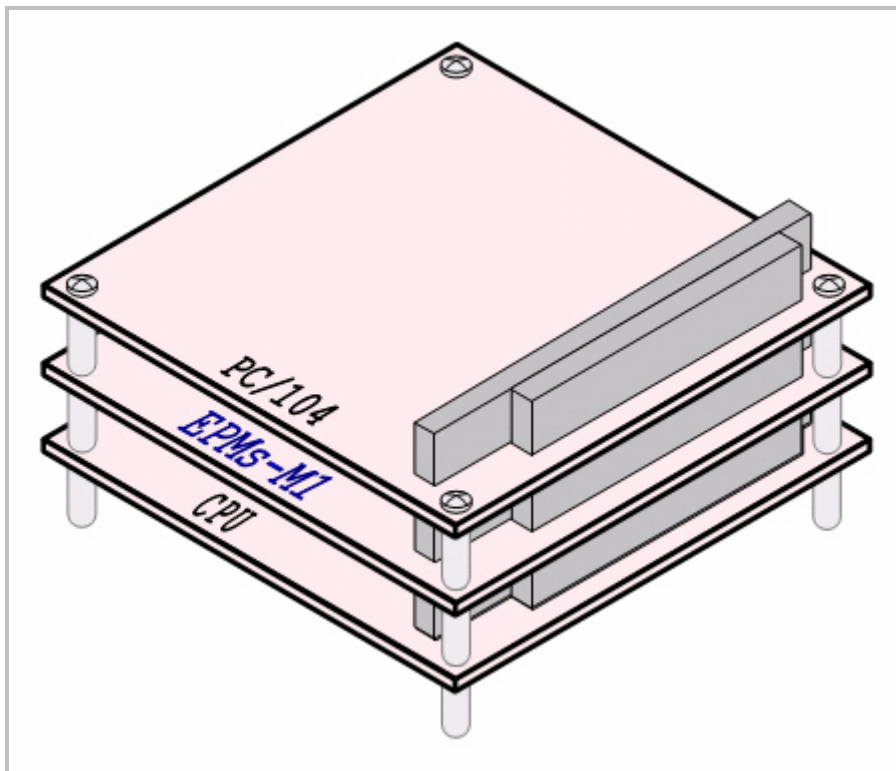

Figure 3. Stacking Example (VL-EPMs-M1B)

External Connectors

VL-EPMS-M1 CONNECTORS

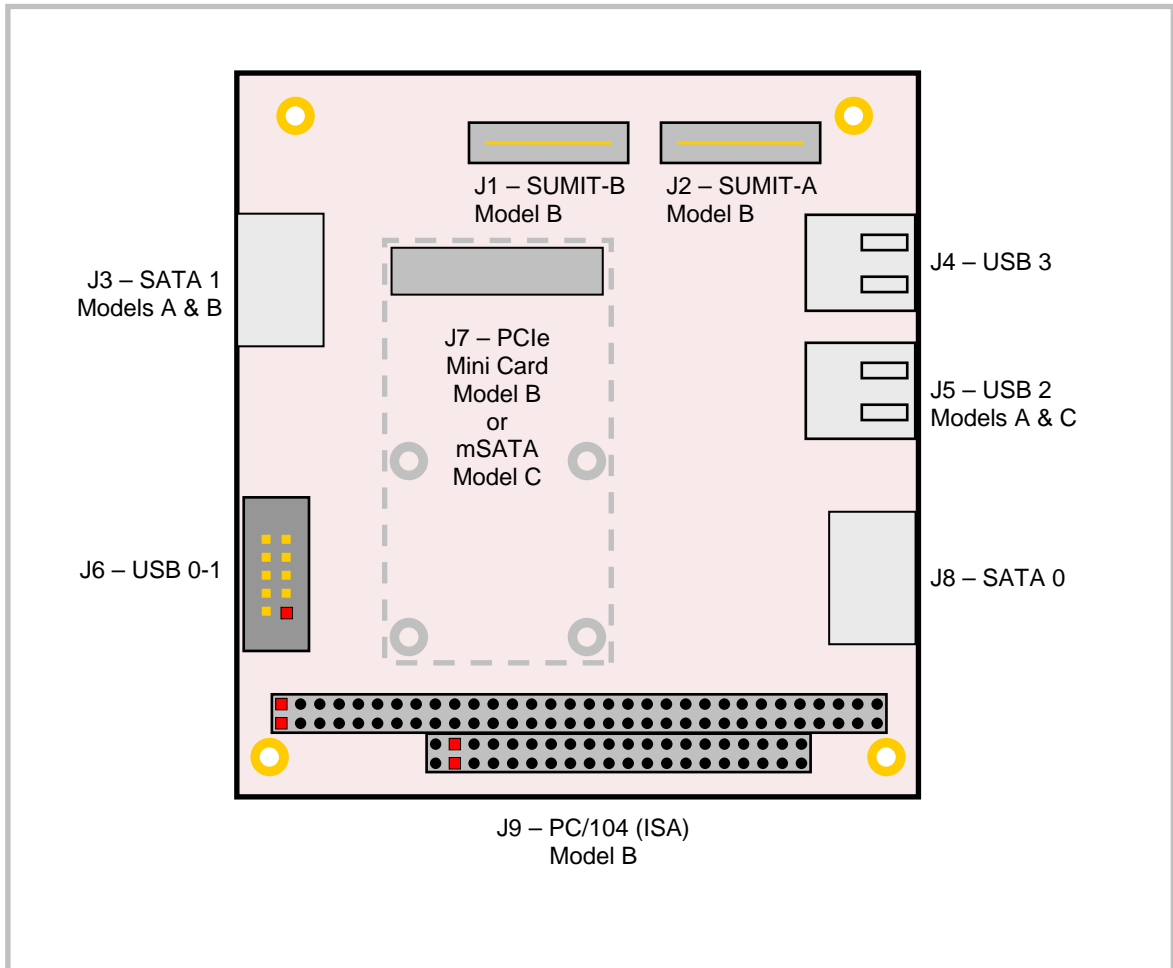

Figure 4. VL-EPMS-M1 Connectors – Top Side

VL-EPMS-M1 CONNECTOR FUNCTIONS AND INTERFACE CABLES

The following table notes the function of each connector, as well as mating connectors and cables, and the page where a detailed pinout or further information is available.

Table 1: Connector Functions and Interface Cables

Connector	Function	Mating Connector	Transition Cable	Cable Description	Pin 1 Location ¹		Page
					x coord.	y coord.	
J1 ²	SUMIT-B Top	Samtec ASP-129646-01	—	—	1.669	3.322	16
J2 ²	SUMIT-A Top	Samtec ASP-129646-01	—	—	2.712	3.322	14
J3	SATA 1 (Models A & B)	Standard SATA	VL-CBR-0701 or VL-CBR-0702 VL-CBR-0401	500 mm 7-pin, straight-to-straight SATA data, friction or mechanical latching ATX to SATA power adapter	0.421	2.525	10
J4	USB 3	USB Type A	—	—	3.036	2.592	10
J5 ³	USB 2	USB Type A	—	—	3.036	1.817	10
J6	USB 0-1	FCI 69830-010LF	VL-CBR-1013	Dual USB transition	0.260	0.955	10
J7 ²	PCIe Mini Card (Model B) or mSATA (Model C)	—	—	—	1.842	2.854	12
J8	SATA 0	Standard SATA	VL-CBR-0701 or VL-CBR-0702 VL-CBR-0401	500 mm 7-pin, straight-to-straight SATA data, friction or mechanical latching ATX to SATA power adapter	3.129	1.260	10
J9 ²	PC/104 (ISA)	AMP 1375795-2	—	—	0.050	0.200	11
J11 ²	SUMIT-B Bottom	Samtec ASP-129637-01	—	—	1.669	3.317	17
J12	SUMIT-A Bottom	Samtec ASP-129637-01	—	—	2.712	3.317	14

1. The PCB origin is the center of the mounting hole located in the lower left, as oriented in Figure 4.
2. VL-EPMS-M1B only.
3. VL-EPMS-M1A & C only.

USB Ports

The VL-EPMs-M1 includes four USB channels. There are two USB ports with standard USB Type A connectors, located on the baseboard at locations J4 and J5 (models A and C). The 10-pin header at location J6 provides two USB channels.

On the VL-EPMs-M1B, the PCIe Mini Card connector at J7 uses one USB channel, leaving three USB channels available for user I/O. On the VL-EPMs-M1B connector J5 is not installed.

All USB connectors are protected against ESD damage.

The USB interface on the VL-EPMs-M1 is UHCI (Universal Host Controller Interface) and EHCI (Enhance Host Controller Interface) compatible, which provides a common industry software/hardware interface.

SATA Ports

The VL-EPMs-M1 provides one or two serial ATA (SATA) ports, which communicate at a rate of up to 3.0 gigabits per second. The SATA connectors at location J3 and J8 are standard 7-pin SATA friction latching connectors (with cable VL-CBR-0701) or mechanical latching (VL-CBR-0702). These connectors are compatible with true latching SATA cables.

Configuring the SATA RAID set is accomplished by entering the RAID Configuration Utility at boot. Press F4 or CTRL+S when prompted.

Power to SATA drives is supplied by the ATX power supply. Note that the standard SATA drive power connector is different than the common 4-pin Molex connector used on IDE drives. Most current ATX power supplies provide SATA connectors, and many SATA drives provide both types of power connectors.

Table 2: SATA Port Pinout

J3 or J8 Pin	Signal Name	Function
1	GND	Ground
2	TX+	Transmit +
3	TX-	Transmit -
4	GND	Ground
5	RX-	Receive -
6	RX+	Receive +
7	GND	Ground

CONFIGURING A SATA RAID SET

To configure a SATA RAID set for two drives, perform the following steps. This procedure assumes that you have installed the VL-EPMs-M1 on a VersaLogic SBC and attached power and data cables to two SATA drives.

Warning! Performing these steps will delete any existing data on the drives.

1. Turn on the host computer.
2. Early in the boot cycle, press CTRL+S or F4 to enter the RAID Configuration Utility.
3. From the Main Menu, select "Create RAID set."
4. Select either RAID0 or RAID1, depending on your application.
 - RAID0 = Striped, combines two hard disks into one
 - RAID1 = Mirrored, copies the contents of one hard disk to another
5. Select whether you want the RAID set to be automatically or manually configured.
6. If you choose to configure the RAID set manually, the utility will prompt you to input the settings for the type of RAID set you selected.
7. Type Y when prompted to create the RAID set.

After the RAID set is created, install the operating system from a CD-ROM drive attached to the CPU board.

PC/104 (ISA) Connector

The PC/104 (ISA) connector (J9) is a pass-through connector only. This connector is present only on the VL-EPMs-M1B.

PCIe Mini Card / mSATA Socket

The socket at location J7 accepts a full-height PCI Express Mini Card (Model B) or an mSATA module (Model C).

The PCIe Mini Card interface includes one PCIe x1 lane, one USB 2.0 channel, and the SMBus interface. The socket is compatible with plug-in Wi-Fi modems, GPS receivers, flash data storage, and other cards for added flexibility. An Intel WiFi Link 5300 PCI Express Mini Card (VL-WD10-CBN) is available from VersaLogic. A WiFi antenna (VL-CBR-ANT01) and a 12" WiFi card to bulkhead RP-SMA transition cable (VL-CBR-0201) are also available. For more information, contact Sales@VersaLogic.com.

The VL-F29 series of mSATA modules provide flash storage of 8 GB, 16 GB, or 32 GB.

To secure a Mini Card or mSATA module to the VL-EPMs-M1 use two screws (M2 x 5 mm, Philips, pan head, 4 mm, stainless) and two washers (M2, split lock, OD 4.4 mm, stainless). Screw and washer sets are available in 10-count packages as part number VL-HDW-107.

Table 3: PCIe Mini Card / mSATA Pinout

Pin	Signal Name	Mini Card Function	mSATA Function
1	WAKE#	Wake	Not connected
2	3.3VAUX	3.3V auxiliary source	3.3V source
3	NC	Not connected	Not connected
4	GND	Ground	Ground
5	NC	Not connected	Not connected
6	1.5V	1.5V power	1.5V power
7	CLKREQ#	Reference clock request	Not connected
8	NC	Not connected	Not connected
9	GND	Ground	Ground
10	NC	Not connected	Not connected
11	REFCLK-	Reference clock input -	Not connected
12	NC	Not connected	Not connected
13	REFCLK+	Reference clock input +	Not connected
14	NC	Not connected	Not connected
15	GND	Ground	Ground
16	NC	Not connected	Not connected
17	NC	Not connected	Not connected
18	GND	Ground	Ground
19	NC	Not connected	Not connected
20	W_DISABLE#	Wireless disable	Not connected
21	GND	Ground	Ground
22	PERST#	Card reset	Not connected
23	PERn0	Lane 0 receive -	Host receiver diff. pair
24	3.3VAUX	3.3V auxiliary source	3.3V source
25	PERp0	Lane 0 receive +	Host receiver diff. pair
26	GND	Ground	Ground
27	GND	Ground	Ground
28	1.5V	1.5V power	1.5V power
29	GND	Ground	Ground
30	SMB_CLK	SMBus clock	Two wire I/F clock

Pin	Signal Name	Mini Card Function	mSATA Function
31	PETn0	PCIe lane 0 transmit –	Host transmitter diff. pair
32	SMB_DATA	SMBus data	Two wire I/F data
33	PETp0	PCIe lane 0 transmit +	Host transmitter diff. pair
34	GND	Ground	Ground
35	GND	Ground	Ground
36	USB_D-	USB data –	Not connected
37	GND	Ground	Ground
38	USB_D+	USB data +	Not connected
39	3.3VAUX	3.3V auxiliary source	3.3V source
40	GND	Ground	Ground
41	3.3VAUX	3.3V auxiliary source	3.3V source
42	LED_WWAN#	Wireless WAN LED	Not connected
43	GND	Ground	Not connected
44	LED_WLAN#	Wireless LAN LED	Not connected
45	NC	Not connected	Not connected
46	LED_WPAN#	Wireless PAN LED	Not connected
47	NC	Not connected	Not connected
48	1.5V	1.5V power	1.5V power
49	NC	Not connected	Not connected
50	GND	Ground	Ground
51	NC	Not connected	Not connected
52	3.3VAUX	3.3V auxiliary source	3.3V source

SUMIT-A Bottom Connector

The table below shows the SUMIT-A Bottom connections to the VL-EPMs-M1. Signals that are not connected are pass-through only. The +5V and ground signals on this connector are available to power the VL-EPMs-M1. This connector is present on all models.

Note: SUMIT technology uses an automatic link alignment feature (also known as “lane shifting”) to eliminate the need for jumpers or switches to identify an expansion module’s PCIe slot number. Signals are not simply passed straight up from the bottom connector to the top on SUMIT modules. Links that are used by the expansion module are automatically selected, and the remaining unused signals are shifted down to the consumed link’s pins on the top connector for use by the next board. This way all high speed signals on the SUMIT interface are point-to-point rather than bussed. Both PCIe and USB signals are subject to auto-alignment. See page 28 of the [SUMIT Specification](#) for an explanation of this feature.

Table 4: SUMIT-A Bottom Connector Pinout

Pin	Signal Name	Function
1	+5V _{SB}	+5V power standby
3	+3.3V	+3.3V power
5	+3.3V	+3.3V power
7	EXPCD_REQ#	ExpressCard request
9	EXPCD_PRSENT#	ExpressCard present
11	USB_OC#0/1	USB0-1 overcurrent flag
13	USB_OC#2/3	USB2-3 overcurrent flag
15	+5V	+5V power
17	USB3+	USB3 data +
19	USB3-	USB3 data –
21	+5V	+5V power
23	USB2+	USB2 data +
25	USB2-	USB2 data –
27	+5V	+5V power
29	USB1+	USB1 data +
31	USB1-	USB1 data –
33	+5V	+5V power
35	USB0+	USB0 data +
37	USB0-	USB0 data –
39	GND	Ground
41	A_PETp0	Link A, lane 0 transmit +
43	A_PETn0	Link A, lane 0 transmit –
45	GND	Ground
47	PERST#	Reset
49	WAKE#	Wake
51	+5V	+5V power

Pin	Signal Name	Function
2	+12V	+12V power
4	SMB/I2C_DATA	SMBus data
6	SMB/I2C_CLK	SMBus clock
8	SMB/I2C_ALERT#	SMBus interrupt line in
10	SPI/uWire_DO	SPI data out from master
12	SPI/uWire_DI	SPI data in to master
14	SPI/uWire_CLK	SPI clock
16	SPI/uWire_CS0#	SPI chip select 0
18	SPI/uWire_CS1#	SPI chip select 1
20	Reserved	Pass-through
22	LPC_DRQ	LPC DRQ
24	LPC_AD0	LPC line 0
26	LPC_AD1	LPC line 1
28	LPC_AD2	LPC line 2
30	LPC_AD3	LPC line 3
32	LPC_FRAME#	LPC frame
34	SERIRQ#	Serial IRQ legacy
36	LPC_PRSENT#/GND	LPC card present
38	CLK_33MHz	33 MHz clock out
40	GND	Ground
42	A_PERp0	Link A, lane 0 receive +
44	A_PERn0	Link A, lane 0 receive –
46	APRSNT#/GND	Link A card present
48	A_CLKp	Link A clock +
50	A_CLKn	Link A clock –
52	GND	Ground

SUMIT-A Top Connector

The table below shows the SUMIT-A Top connections to the VL-EPMs-M1. Signals that are not connected are pass-through only. The +5V signals on this connector are available to power the VL-EPMs-M1. This connector is present only on the VL-EPMs-M1B. (See the SUMIT "lane shifting" note on page 14.)

Table 5: SUMIT-A Top Connector Pinout

Pin	Signal Name	Function
1	+5V _{SB}	+5V power standby
3	+3.3V	+3.3V power
5	+3.3V	+3.3V power
7	EXPCD_REQ#	ExpressCard request
9	EXPCD_PRSENT#	ExpressCard present
11	NC	Not connected
13	NC	Not connected
15	+5V	+5V power
17	NC	Not connected
19	NC	Not connected
21	+5V	+5V power
23	NC	Not connected
25	NC	Not connected
27	+5V	+5V power
29	NC	Not connected
31	NC	Not connected
33	+5V	+5V power
35	NC	Not connected
37	NC	Not connected
39	GND	Ground
41	A_PETp0	Link A, lane 0 transmit +
43	A_PETn0	Link A, lane 0 transmit –
45	GND	Ground
47	PERST#	Reset
49	WAKE#	Wake
51	+5V	+5V power

Pin	Signal Name	Function
2	+12V	+12V power
4	SMB/I2C_DATA	SMBus data
6	SMB/I2C_CLK	SMBus clock
8	SMB/I2C_ALERT#	SMBus interrupt line in
10	SPI/μWire_DO	SPI data out from master
12	SPI/μWire_DI	SPI data in to master
14	SPI/μWire_CLK	SPI clock
16	SPI/μWire_CS0#	SPI chip select 0
18	SPI/μWire_CS1#	SPI chip select 1
20	Reserved	Pass-through
22	Reserved	Pass-through
24	LPC_AD0	LPC line 0
26	LPC_AD1	LPC line 1
28	LPC_AD2	LPC line 2
30	LPC_AD3	LPC line 3
32	LPC_FRAME#	LPC frame
34	SERIRQ#	Serial IRQ legacy
36	LPC_PRSENT#/GND	LPC card present
38	CLK_33MHz	33 MHz clock out
40	GND	Ground
42	A_PERp0	Link A, lane 0 receive +
44	A_PERn0	Link A, lane 0 receive –
46	APRSNT#/GND	Link A card present
48	A_CLKp	Link A clock +
50	A_CLKn	Link A clock –
52	GND	Ground

SUMIT-B Top Connector

The table below shows the SUMIT-B Top connections to the VL-EPMs-M1. Signals that are not connected are pass-through only. The +5V signals on this connector are available to power the VL-EPMs-M1. This connector is present only on the VL-EPMs-M1B. (See the SUMIT "lane shifting" note on page 14.)

Table 6: SUMIT-B Top Connector Pinout

Pin	Signal Name	Function
1	GND	Ground
3	B_PETp0	Link B, lane 0 transmit +
5	B_PETn0	Link B, lane 0 transmit –
7	GND	Ground
9	NC	Not connected
11	NC	Not connected
13	NC	Not connected
15	C_PETp0	Link C, lane 0 transmit +
17	C_PETn0	Link C, lane 0 transmit –
19	GND	Ground
21	C_PETp1	Link C, lane 1 transmit +
23	C_PETn1	Link C, lane 1 transmit –
25	GND	Ground
27	NC	Not connected
29	NC	Not connected
31	GND	Ground
33	NC	Not connected
35	NC	Not connected
37	GND	Ground
39	PERST#	Reset
41	Reserved	Pass-through
43	+5V	+5V power
45	+5V	+5V power
47	+5V	+5V power
49	+5V	+5V power
51	+5V	+5V power

Pin	Signal Name	Function
2	GND	Ground
4	B_PERp0	Link B, lane 0 receive +
6	B_PERn0	Link B, lane 0 receive –
8	NC	Not connected
10	NC	Not connected
12	NC	Not connected
14	GND	Ground
16	C_PERp0	Link C, lane 0 receive +
18	C_PERn0	Link C, lane 0 receive –
20	GND	Ground
22	C_PERp1	Link C, lane 1 receive +
24	C_PERn1	Link C, lane 1 receive –
26	GND	Ground
28	NC	Not connected
30	NC	Not connected
32	GND	Ground
34	NC	Not connected
36	NC	Not connected
38	GND	Ground
40	WAKE#	Wake
42	Reserved	Pass-through
44	Reserved	Pass-through
46	+3.3V	+3.3V power
48	+3.3V	+3.3V power
50	+3.3V	+3.3V power
52	+5V _{SB}	+5V standby power

SUMIT-B Bottom Connector

The table below shows the SUMIT-B Bottom connections to the VL-EPMs-M1. Signals that are not connected are pass-through only. The +5V and ground signals on this connector are available to power the VL-EPMs-M1. This connector is present only on the VL-EPMs-M1B. (See the SUMIT "lane shifting" note on page 14.)

Table 7: SUMIT-B Bottom Connector Pinout

Pin	Signal Name	Function
1	GND	Ground
3	B_PETp0	Link B, lane 0 transmit +
5	B_PETn0	Link B, lane 0 transmit –
7	GND	Ground
9	C_CLKp	Link C clock +
11	C_CLKn	Link C clock –
13	CPRSNT#/GND	Link C card present
15	C_PETp0	Link C, lane 0 transmit +
17	C_PETn0	Link C, lane 0 transmit –
19	GND	Ground
21	C_PETp1	Link C, lane 1 transmit +
23	C_PETn1	Link C, lane 1 transmit –
25	GND D	Ground
27	C_PETp2	Link C, lane 2 transmit +
29	C_PETn2	Link C, lane 2 transmit –
31	GND	Ground
33	C_PETp3	Link C, lane 3 transmit +
35	C_PETn3	Link C, lane 3 transmit –
37	GND	Ground
39	PERST#	Reset
41	Reserved	Pass-through
43	+5V	+5V power
45	+5V	+5V power
47	+5V	+5V power
49	+5V	+5V power
51	+5V	+5V power

Pin	Signal Name	Function
2	GND	Ground
4	B_PERp0	Link B, lane 0 receive +
6	B_PERn0	Link B, lane 0 receive –
8	BPRSNT#/GND	Link B present
10	B_CLKp	Link B clock +
12	B_CLKn	Link B clock –
14	GND	Ground
16	C_PERp0	Link C, lane 0 receive +
18	C_PERn0	Link C, lane 0 receive –
20	GND	Ground
22	C_PERp1	Link C, lane 1 receive +
24	C_PERn1	Link C, lane 1 receive –
26	GND	Ground
28	C_PERp2	Link C, lane 2 receive +
30	C_PERn2	Link C, lane 2 receive –
32	GND	Ground
34	C_PERp3	Link C, lane 3 receive +
36	C_PERn3	Link C, lane 3 receive –
38	GND	Ground
40	WAKE#	Wake
42	Reserved	Pass-through
44	Reserved	Pass-through
46	+3.3V	+3.3V power
48	+3.3V	+3.3V power
50	+3.3V	+3.3V power
52	+5V _{SB}	+5V standby power

Appendix A – References



SUMIT Interface

[SUMIT Specification](#)

PC/104 Interface

[PC/104 Specification](#)