

# Reference Manual

DOC. REV. 5/12/2010

---

## VL-EPMs-U1

SUMIT-ISM™ Serial  
Communications + GPS Module



**VERSA**LOGIC  
CORPORATION



[WWW.VERSALOGIC.COM](http://WWW.VERSALOGIC.COM)

4211 West 11th Ave.  
Eugene, OR 97402  
(541) 485-8575  
Fax (541) 485-5712

Copyright © 2010 VersaLogic Corp. All rights reserved.

**Notice:**

Although every effort has been made to ensure this document is error-free, VersaLogic makes no representations or warranties with respect to this product and specifically disclaims any implied warranties of merchantability or fitness for any particular purpose.

VersaLogic reserves the right to revise this product and associated documentation at any time without obligation to notify anyone of such changes.

PC/104 and the PC/104 logo are trademarks of the PC/104 Consortium. SUMIT, ISM, SUMIT-ISM, and the SUMIT logo are trademarks of the Small Form Factor Special Interest Group (SFF-SIG). All other product names and trademarks, registered trademarks, or service marks are property of their respective owners.

# Product Release Notes

Rev 1.00 – Commercial Release.

## Support Page

The VL-EPMs-U1 support page, at <http://www.versalogic.com/private/epmsu1support.asp>, contains additional information and resources for this product including:

- Reference Manual (PDF format)
- Device drivers
- Datasheets and manufacturers' links for chips used in this product
- Photograph of the circuit board
- BIOS information and upgrades
- Utility routines and benchmark software

This is a private page for VL-EPMs-U1 users that can be accessed only by entering this URL address directly. It cannot be reached from the VersaLogic public website.

The VersaTech KnowledgeBase is an invaluable resource for resolving technical issues with your VersaLogic product.

[VersaTech KnowledgeBase](#)

# Contents

---

<b>Introduction .....</b>	<b>1</b>
Features .....	1
Technical Specifications .....	2
Block Diagram .....	3
RoHS-Compliance .....	4
About RoHS.....	4
Warnings.....	4
Electrostatic Discharge .....	4
Technical Support.....	5
Repair Service.....	5
<b>Physical Description .....</b>	<b>6</b>
Dimensions and Mounting.....	6
Hardware Assembly.....	8
Stacking Restrictions .....	9
External Connectors.....	10
VL-EPMs-U1 Connectors.....	10
VL-EPMs-U1 Connector Functions and Interface Cables.....	11
Jumper Blocks.....	12
Jumpers As-shipped Configuration.....	12
Jumper Summary .....	13
<b>Operation .....</b>	<b>14</b>
Serial Ports.....	14
Serial Port Connectors .....	15
GPS and Antenna.....	18
Antenna Connector (J5).....	18
Battery Back-up .....	18
Coordinate Systems .....	20
Performance Characteristics .....	21
Start-up .....	22
SUMIT-A Top Connector (J6).....	23
SUMIT-B Top Connector (J7).....	24
PC/104 (ISA) Connector (J10) .....	25
SUMIT-B Bottom Connector (J11) .....	25
SUMIT-A Bottom Connector (J12).....	26
<b>Appendix A – References .....</b>	<b>27</b>

## Features

The VL-EPMs-U1 is an embedded serial communications module with global positioning system (GPS) capability. Based on the SUMIT-ISM form factor, the VL-EPMs-U1 supports SUMIT and PC/104 stackable expansion buses on a 95 mm x 96 mm (3.76" x 3.78") footprint. Configurations and feature sets include:

<i>Model</i>	<i>Availability</i>	<i>Serial Channels</i>	<i>GPS</i>	<i>Connectors</i>
VL-EPMs-U1A	Standard	4	No	SUMIT-A
VL-EPMs-U1B	Standard	6	No	SUMIT-A
VL-EPMs-U1C	Standard	4	No	SUMIT-AB + ISA
VL-EPMs-U1D	Special Order	6	No	SUMIT-AB + ISA
VL-EPMs-U1E	Standard	2*	Yes	SUMIT-A
VL-EPMs-U1F	Special Order	4*	Yes	SUMIT-A
VL-EPMs-U1G	Special Order	2*	Yes	SUMIT-AB + ISA
VL-EPMs-U1H	Special Order	4*	Yes	SUMIT-AB + ISA

\* Indicates the number of serial channels available for user I/O. The two serial channels (COM3-4) dedicated to the GPS interface are not included in this number.

All boards include the following features:

- Transient Voltage Suppression (TVS) devices on I/O interfaces for protection against power spikes and surges
- Designed to provide -40° to +85°C operation for reliable use in harsh environments
- Full compliance with EU Directive 2002/95/EC (RoHS) for devices used in Europe
- SUMIT-ISM (Legacy Type 1) form factor

The VL-EPMs-U1 features high-reliability design and construction. All VL-EPMs-U1 boards are subjected to functional testing and are backed by a limited two-year warranty. Careful parts sourcing and US-based technical support ensure the highest possible quality, reliability, service, and product longevity for this exceptional board.

## Technical Specifications

**Board Size:**

ISM™/PC/104™ standard:  
90 mm x 96 mm (3.55" x 3.78")

**Power Requirements:**

+5V @ 140 mA (700 mW)

**Stackable Bus:**

SUMIT: SUMIT-A, SUMIT-B\*  
PC/104\*: ISA (pass-through only)

**Operating Temperature:**

-40° to +85°C

**Storage Temperature:**

-40° to +85°C

**Airflow Requirements:**

Free air from -40° to +85°C

**COM1/COM2:**

RS-232, 16C550A compatible, 115 Kbps, full  
handshaking to support DB-9 connector  
(TVS protected)

**COM3/COM4:**

RS-232/422/485, 16C550A compatible, 460  
Kbps. 4-line RS-232: Tx/Rx Data and  
CTS/RTS. TVS protected. Consumed by  
GPS module in GPS versions.

**COM5/COM6:**

RS-232/422/485, 16C550A compatible, 460  
Kbps. 4-line RS-232: Tx/Rx Data and  
CTS/RTS. TVS protected.

**GPS\*:**

Trimble® Lassen® iQ GPS module  
- 12-channel GPS functionality  
- Supports NMEA 0183, TSIP, TAIP, and  
DGPS protocols  
- Consumes COM3 and COM4  
- Battery-backed almanac (estimated  
power-off battery life 10 yrs)

**Weight:**

VL-EPMs-U1A – 0.041 kg (0.088 lb)  
VL-EPMs-U1B – 0.043 kg (0.096 lb)  
VL-EPMs-U1C – 0.066 kg (0.146 lb)  
VL-EPMs-U1E – 0.054 kg (0.120 lb)

\* *Optional*

Data represents standard operation at +25°C with +5V supply unless otherwise noted.  
Specifications are subject to change without notification.

SUMIT Resources		
Form Factor: SUMIT-ISM (Legacy Type 1)		
	SUMIT A	SUMIT B*
PCIe x1	–	–
PCIe x4	–	–
USB	–	–
ExpressCard	–	–
LPC	1	–
SPI / µWire	–	–
SMBus / I <sup>2</sup> C	–	–
+12V	–	–
+5V	✓	✓
+5V <sub>sb</sub>	–	–
+3.3V	–	–

# Block Diagram

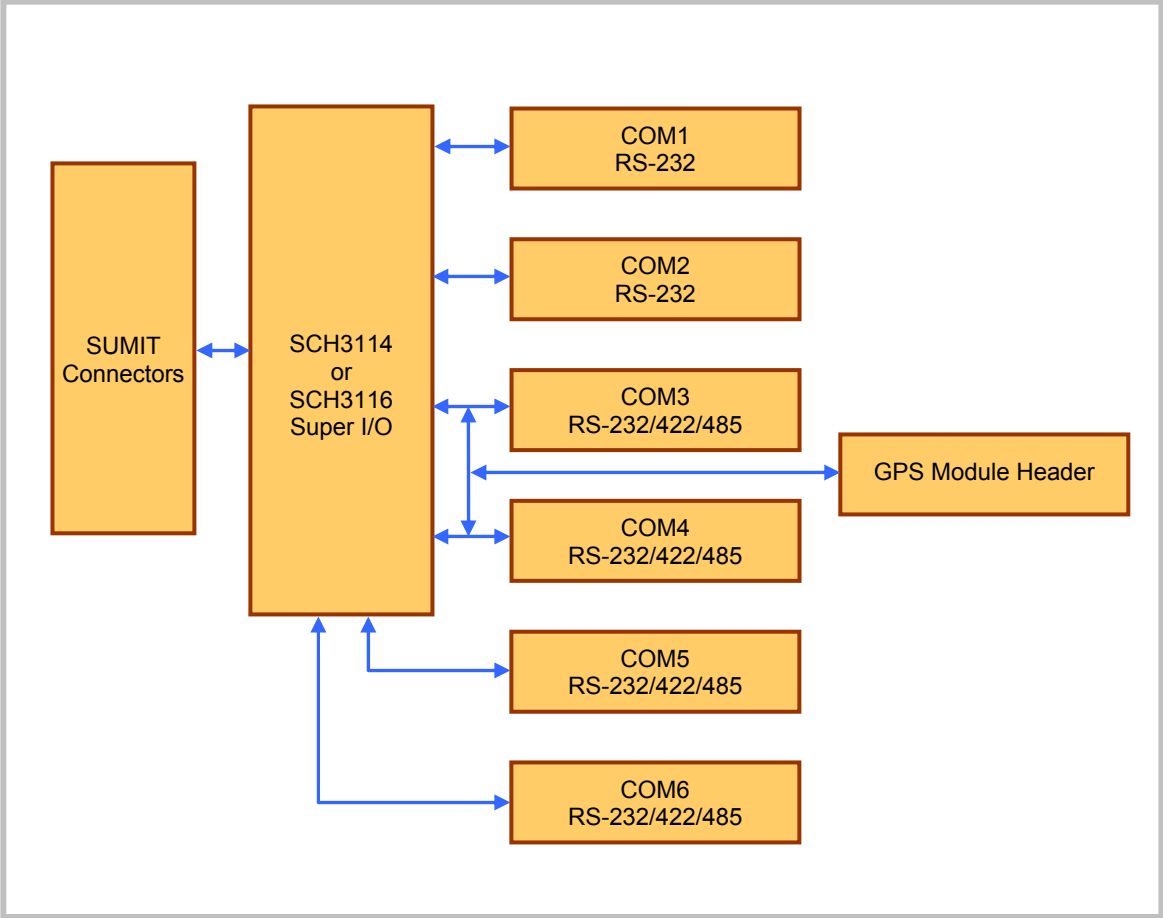

Figure 1. VL-EPMs-U1 Block Diagram

## RoHS-Compliance

The VL-EPMs-U1 is RoHS-compliant.

### ABOUT ROHS

In 2003, the European Union issued Directive 2002/95/EC regarding the Restriction of the use of certain Hazardous Substances (RoHS) in electrical and electronic equipment.

The RoHS directive requires producers of electrical and electronic equipment to reduce to acceptable levels the presence of six environmentally sensitive substances: lead, mercury, cadmium, hexavalent chromium, and the presence of polybrominated biphenyls (PBB) and polybrominated diphenyl ethers (PBDE) flame retardants, in certain electrical and electronic products sold in the European Union (EU) beginning July 1, 2006.

VersaLogic Corp. is committed to supporting customers with high-quality products and services meeting the European Union's RoHS directive.

## Warnings

### ELECTROSTATIC DISCHARGE

Electrostatic discharge (ESD) can damage boards, disk drives, and other components. The circuit board must only be handled at an ESD protective workstation. If an approved station is not available, some measure of protection can be provided by wearing a grounded antistatic wrist strap. Keep all plastic away from the board. Do not slide the board over any surface.

After removing the board from its protective wrapper, place the board on a grounded, static-free surface, component side up. Use an antistatic foam pad if available.

The board should always be protected inside a closed metallic antistatic envelope during shipment or storage.

## Technical Support

If you are unable to solve a problem after reading this manual, please visit the VL-EPMs-U1 product support web page (see below). The support page provides links to component datasheets and device drivers.

### [VL-EPMs-U1 Support Page](http://www.versalogic.com/private/epmsu1support.asp)

<http://www.versalogic.com/private/epmsu1support.asp>

The VersaTech KnowledgeBase contains a wealth of technical information about VersaLogic products, along with product advisories. Click the link below to see all KnowledgeBase articles related to the VL-EPMs-U1.

### [VersaTech KnowledgeBase](#)

If you have further questions, contact VersaLogic Technical Support at (541) 485-8575. VersaLogic support engineers are also available via e-mail at [Support@VersaLogic.com](mailto:Support@VersaLogic.com).

#### REPAIR SERVICE

If your product requires service, you must obtain a Returned Material Authorization (RMA) number by calling (541) 485-8575.

Please provide the following information:

- Your name, the name of your company, your phone number, and your e-mail address
- The name of a technical contact if any questions arise
- Quantity of items being returned
- The model and serial number (barcode) of each item
- A detailed description of the problem
- Steps you have taken to resolve or recreate the problem
- The return shipping address

#### Warranty Repair

All parts and labor charges are covered, including return shipping charges for UPS Ground delivery to United States addresses.

#### Non-warranty Repair

All non-warranty repairs are subject to diagnosis and labor charges, parts charges, and return shipping fees. Please specify the shipping method you prefer and provide a purchase order number for invoicing the repair.

#### Note

Please mark the RMA number clearly on the outside of the box before returning. Failure to do so can delay the processing of your return.

## Dimensions and Mounting

The VL-EPMs-U1 complies with SUMIT-ISM (Legacy Type 1) form factor, which provides for specific mounting hole and stackable bus locations as shown in the diagram below.

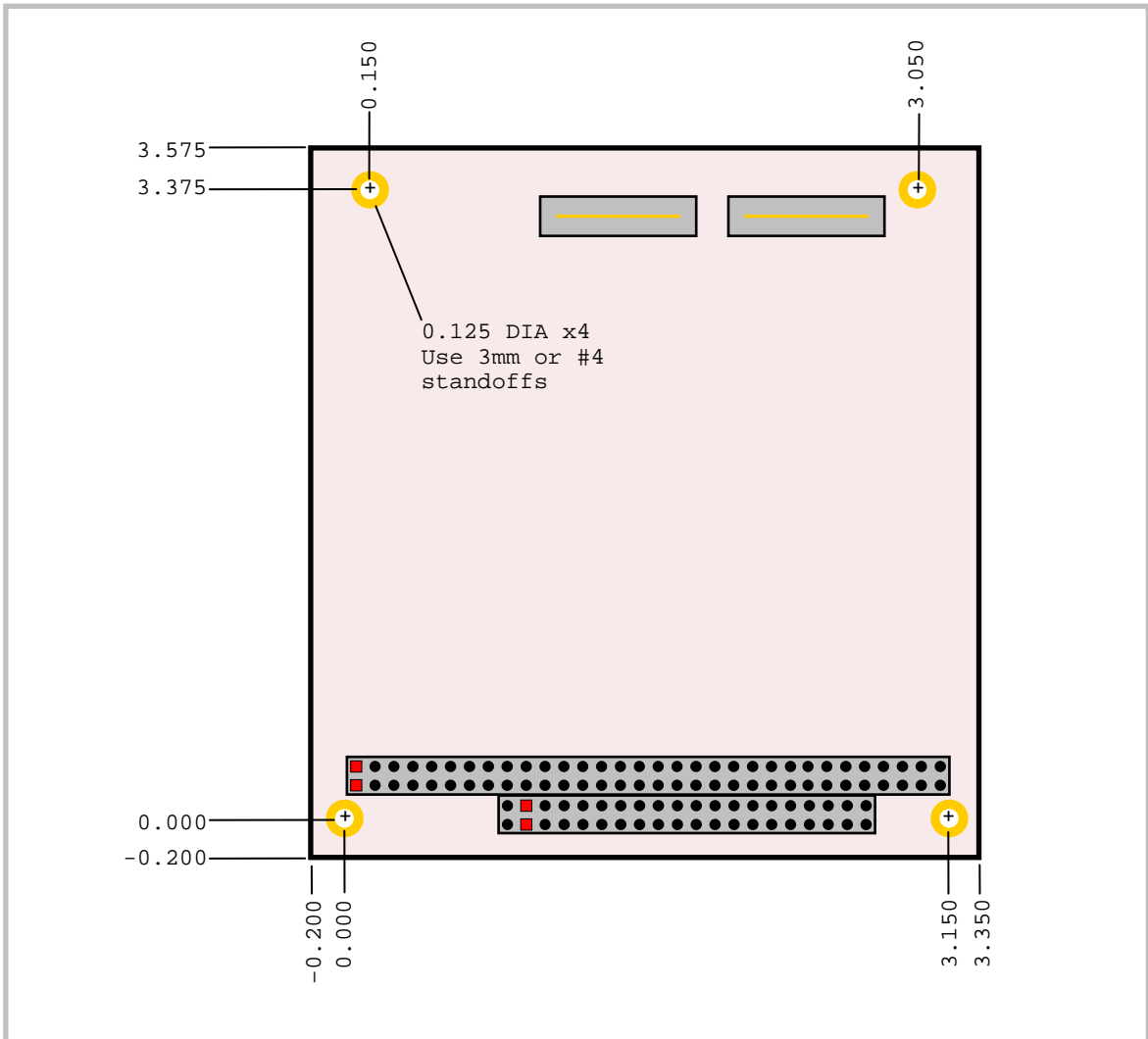

**Figure 2. VL-EPMs-U1 Dimensions and Mounting Holes**  
(Not to scale. All dimensions in inches.)

**Caution** The board must be supported at all four mounting points to prevent excessive flexing when expansion modules are mated and detached. Flex damage caused by excessive force on an improperly mounted circuit board is not covered under the product warranty.

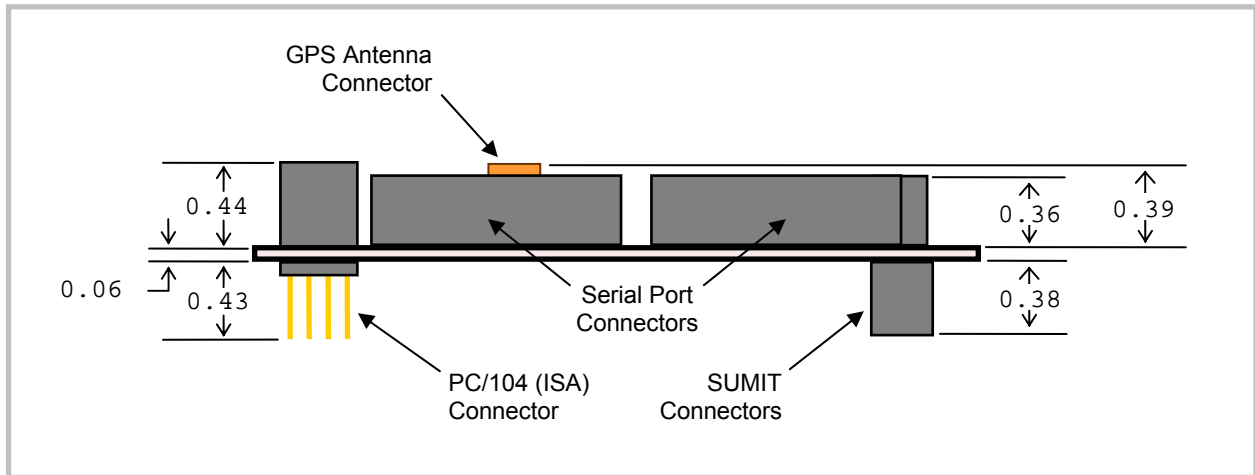

**Figure 3. VL-EPMs-U1x Height Dimensions**

*(Not to scale. All dimensions in inches.)*

**Note** Not all connectors are present on all models.

## HARDWARE ASSEMBLY

The VL-EPMs-U1 comes in a variety of configurations that use SUMIT-A only, SUMIT-A and SUMIT-B, and PC/104 (ISA) connectors. The module can be added to the middle or top of the stack, above any SUMIT boards and below any PC/104 boards.

The entire assembly can sit on a table top or be secured to a base plate. When bolting the unit down, make sure to secure all four standoffs to the mounting surface to prevent circuit board flexing. Standoffs are secured to the top circuit board using four pan head screws. Standoffs and screws are available (VL-HDW-105/VL-HDW-106). Note that the standoffs in this kit are 15.24 mm (0.6") and must not be mixed with 15 mm (0.59") standoffs (VL-HDW-100/VL-HDW-101).

An extractor tool is available (part number VL-HDW-201) to separate modules from the stack. Use caution when using the extractor tool so as not to damage any board components.

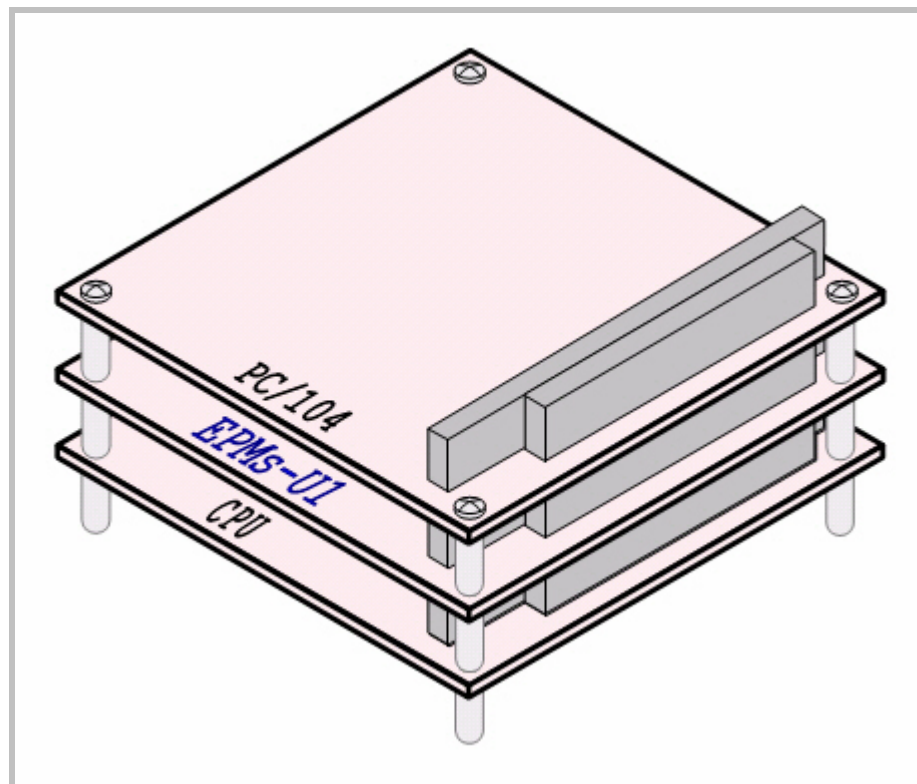

Figure 4. Stacking Example

## STACKING RESTRICTIONS

The VL-EPMs-U1 can be used with any SUMIT-enabled VersaLogic CPU board, though some restrictions apply, as described below.

### VL-EPMs-21 and VL-EPICs-36 Restrictions

The following restrictions apply when using the VL-EPMs-21 or VL-EPICs-36:

- A maximum of two VL-EPMs-U1 boards are supported in the stack.
- When two VL-EPMs-U1 boards are in the stack, one must be configured with a base address of 0x4E. The other board must be configured to 0x162E or 0x164E. Address 0x2E is reserved for the CPU board's Super I/O.
- I/O base address availability is limited. Generally, each base address option is port specific. Eighteen I/O base addresses are available to all ports, but address options for a particular port are limited to three.
- Interrupts can be shared among serial ports on the same VL-EPMs-U1 board, but not shared among serial ports on different boards (that is, serial ports originating from different super I/O chips).
- The serial ports on the VL-EPMs-U1 must be added manually in Windows using the Add Hardware Wizard and the Device Manager. The module is not plug-and-play.
- BIOS console redirection to VL-EPMs-U1 serial ports cannot be activated using the Ctrl-C keyboard combination. However, the OS can redirect the console to VL-EPMs-U1 ports.

### Additional VL-EPICs-36 Restrictions

The following restrictions pertain to the VL-EPICs-36 only:

- A maximum of three I/O ranges can be allocated to VL-EPMs-U1 serial ports. You should configure the ports to use contiguous I/O space to best utilize these decode ranges. The following base addresses are exempt from this restriction: 3F8, 2F8, 208, and 200.
- Including on-board serial ports, a maximum of 16 ports can be configured. The system will display a warning if the BIOS cannot allocate enough I/O space.

# External Connectors

## VL-EPMS-U1 CONNECTORS

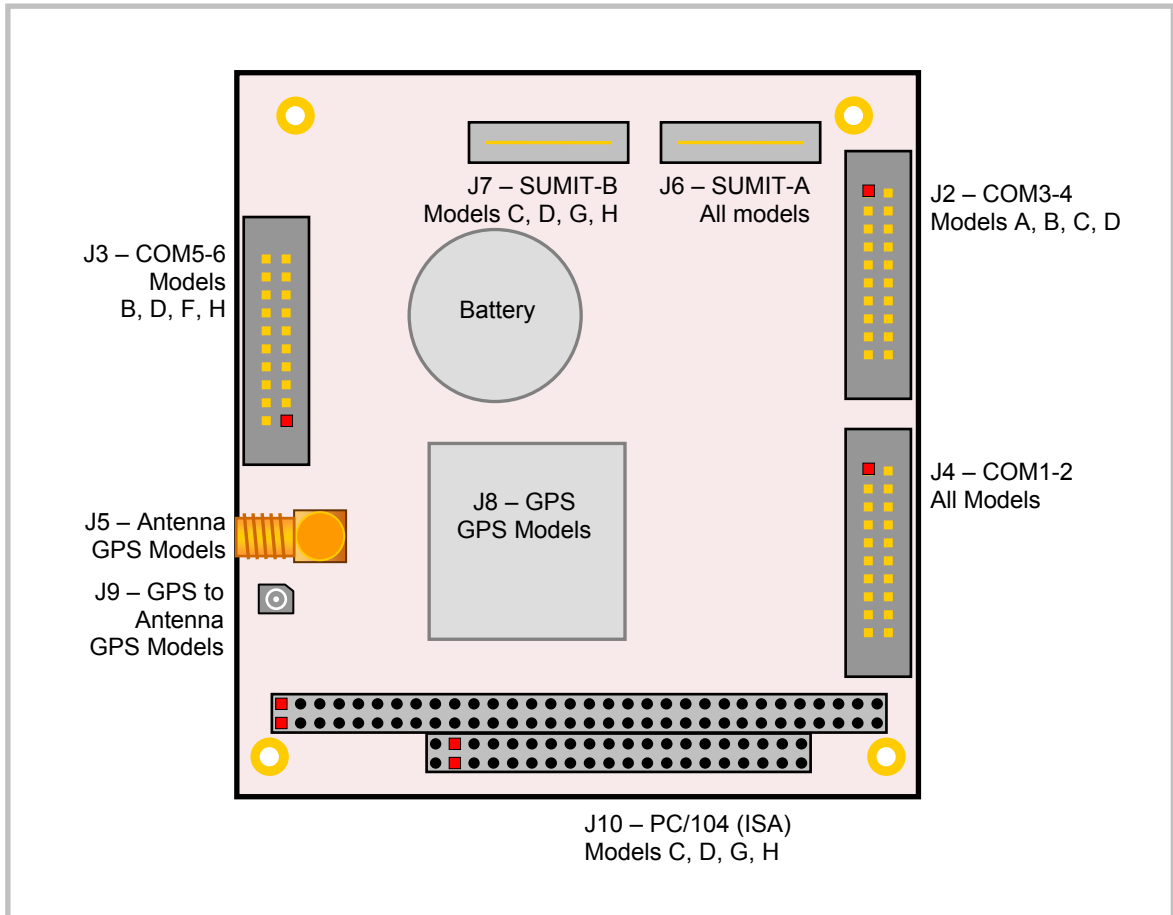

Figure 5. VL-EPMS-U1 Connectors – Top Side

## VL-EPMs-U1 CONNECTOR FUNCTIONS AND INTERFACE CABLES

The following table notes the function of each connector, as well as mating connectors and cables, and the page where a detailed pinout or further information is available.

**Table 1: Connector Functions and Interface Cables**

Connector	Function	Mating Connector	Transition Cable	Cable Description	Pin 1 Location <sup>1</sup>		Page
					x coord.	y coord.	
J1	Not installed	—	—	—	0.614	3.401	—
J2	COM3/4	3M 89120-0101	VL-CBR-2001	12" 20-pin socket to two DB-9	3.099	2.969	16
J3	COM5/6	3M 89120-0101	VL-CBR-2001	12" 20-pin socket to two DB-9M	0.047	1.723	17
J4	COM1/2	3M 89120-0101	VL-CBR-2001	12" 20-pin socket to two DB-9M	3.099	1.513	15
J5	GPS Antenna	SubMiniature A (SMA) male	VL-CBR-ANT02	5m Trimble antenna	—	—	18
J6	SUMIT-A (Top)	Samtec ASP-129646-01	—	—	2.712	3.322	23
J7	SUMIT-B (Top)	Samtec ASP-129646-01	—	—	1.669	3.322	24
J8	GPS header	—	—	(GPS)	—	—	18
J9	GPS to Antenna	—	—	(Supplied with GPS)	—	—	18
J10	PC/104 ISA	AMP 1375795-2	—	—	0.050	0.200	25
J11	SUMIT-B (Bottom)	Samtec ASP-129637-01	—	—	1.669	3.317	25
J12	SUMIT-A (Bottom)	Samtec ASP-129637-01	—	—	2.712	3.317	26

1. The PCB origin is the center of the mounting hole located in the lower left, as oriented in Figure 5.

# Jumper Blocks

## JUMPERS AS-SHIPED CONFIGURATION

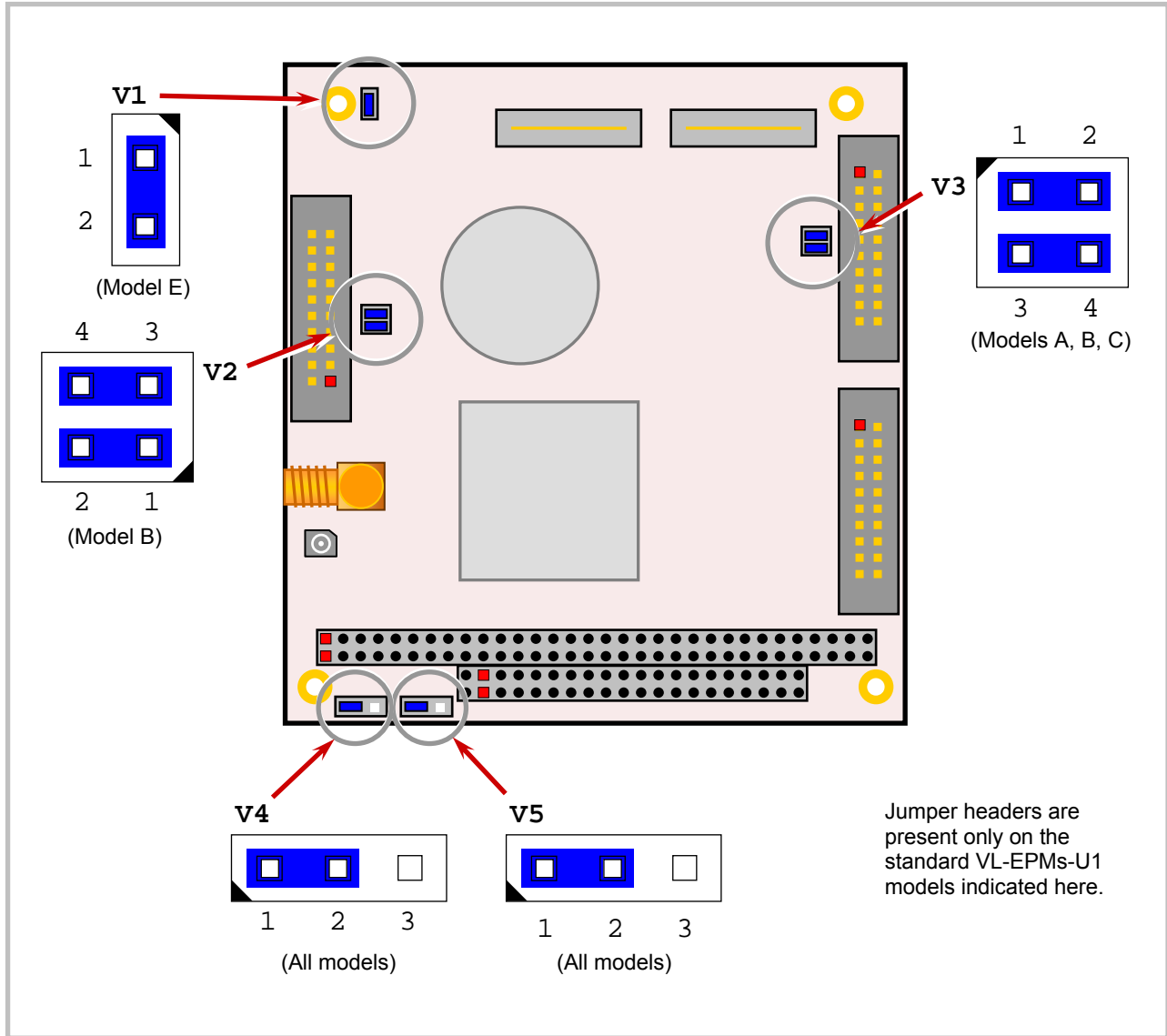

Figure 6. As-shipped Jumper Configuration

## JUMPER SUMMARY

Not all jumper headers are present on all standard VL-EPMs-U1 models (A, B, C, and E), as indicated in the Jumper Summary table.

**Table 2: Jumper Summary**

Jumper Block	Description	As Shipped	Page															
V1[1-2]	<p><b>GPS Backup power.</b> This jumper header is installed on the VL-EPMs-U1B and E only.</p> <p>In – GPS almanac backup power is connected Out – GPS almanac backup power is not connected</p> <p>Either through an installed lithium battery or external power source via J1, backup power can optionally be supplied to the GPS unit to maintain its almanac, ephemeris, and last position for faster initial position fixes upon system power up (10 seconds typical).</p>	In (Model E only)	—															
V2[1-2]	<p><b>COM5 RS-422/485 Termination Resistor.</b> This jumper header is installed on the VL-EPMs-U1B only.</p> <p>In – COM5 terminated Out – No termination</p> <p>Installing a jumper places a 120 ohm terminating resistor across the COM5 RxD+/RxD- differential pair.</p>	In (Model B only)	17															
V2[3-4]	<p><b>COM6 RS-422/485 Termination Resistor.</b> This jumper header is installed on the VL-EPMs-U1B only.</p> <p>In – COM6 terminated Out – No termination</p> <p>Installing a jumper places a 120 ohm terminating resistor across the COM6 RxD+/RxD- differential pair.</p>	In (Model B only)	17															
V3[1-2]	<p><b>COM3 RS-422/485 Termination Resistor.</b> This jumper header is installed on the VL-EPMs-U1A, B, and C only.</p> <p>In – COM3 terminated Out – No termination</p> <p>Installing a jumper places a 120 ohm terminating resistor across the COM3 RxD+/RxD- differential pair.</p>	In (Models A, B, and C only)	16															
V3[3-4]	<p><b>COM4 RS-422/485 Termination Resistor.</b> This jumper header is installed on the VL-EPMs-U1A, B, and C only.</p> <p>In – COM4 terminated Out – No termination</p> <p>Installing a jumper places a 120 ohm terminating resistor across the COM4 RxD+/RxD- differential pair.</p>	In (Models A, B, and C only)	16															
V4-V5	<p><b>Super I/O Base Address Selector.</b> These jumper headers are installed on all VL-EPMs-U1 models.</p> <p><b>SIO Base Address</b></p> <table border="1"> <thead> <tr> <th>Address</th> <th>V4</th> <th>V5</th> </tr> </thead> <tbody> <tr> <td>0x2E</td> <td>2-3</td> <td>1-2</td> </tr> <tr> <td>0x4E</td> <td>1-2</td> <td>1-2</td> </tr> <tr> <td>0x162E</td> <td>2-3</td> <td>2-3</td> </tr> <tr> <td>0x164E</td> <td>1-2</td> <td>2-3</td> </tr> </tbody> </table> <p>Selects the base address of the board.</p>	Address	V4	V5	0x2E	2-3	1-2	0x4E	1-2	1-2	0x162E	2-3	2-3	0x164E	1-2	2-3	0x4E V4[1-2] V5[1-2] (All models)	—
Address	V4	V5																
0x2E	2-3	1-2																
0x4E	1-2	1-2																
0x162E	2-3	2-3																
0x164E	1-2	2-3																

## Serial Ports

The VL-EPMs-U1 can be configured with up to six serial ports, COM1-6, depending on the model. The table below describes serial port configurations.

**Table 3: Serial Port Configurations**

Port	Type	Connector	Models
COM1/2	RS-232, 16C550A compatible, 115 Kbps, all handshake lines implemented	J4	A, B, C, D, E, F, G, H
COM3/4	RS-232/422/485, 16C550A compatible, 460 Kbps, 4-wire RS-232 (only CTS and RTS handshaking); consumed by GPS in GPS-enabled models	J2	A, B, C, D
COM5/6	RS-232/422/485, 16C550A compatible, 460 Kbps, 4-wire RS-232 (only CTS and RTS handshaking)	J3	B, D, F, H

These connectors are protected against ESD damage.

## SERIAL PORT CONNECTORS

### COM1 and COM2 (J4)

The interface to COM1 and COM2 is provided by connector J4. VL-CBR-2001 connects to J4 and provides two DB-9M connectors. The pinouts for these connectors are shown below.

**Table 4: COM1 and COM2 Pinouts**

J4 Pin	RS-232	VL-CBR-2001 DB-9 COM1 Pin
1	DCD	1
2	DSR	6
3	RXD#	2
4	RTS	7
5	TXD#	3
6	CTS	8
7	DTR	4
8	RI	9
9	Ground	5
10	NC	—

J4 Pin	RS-232	VL-CBR-2001 DB-9 COM2 Pin
11	DCD	1
12	DSR	6
13	RXD#	2
14	RTS	7
15	TXD#	3
16	CTS	8
17	DTR	4
18	RI	9
19	Ground	5
20	NC	—

## COM3 and COM4 (J2)

The interface to COM3 and COM4 is provided by connector J2. VL-CBR-2001 connects to J2 and provides two DB-9M connectors. The pinouts for these connectors are shown below.

**Table 5: COM3 and COM4 Pinouts**

J2 Pin	RS-232	RS-422	RS-485	VL-CBR-2001 DB-9 COM3 Pin
1	NC	NC	NC	1
2	NC	NC	NC	6
3	RxD#	RxD-	RxD-	2
4	RTS	TxD+	TxD+	7
5	TxD#	TxD-	TxD-	3
6	CTS	RxD+	RxD+	8
7	+5V pull-up	+5V pull-up	+5V pull-up	4
8	NC	NC	NC	9
9	Ground	Ground	Ground	5
10	NC	NC	NC	—

J2 Pin	RS-232	RS-422	RS-485	VL-CBR-2001 DB-9 COM4 Pin
11	NC	NC	NC	1
12	NC	NC	NC	6
13	RxD#	RxD-	RxD-	2
14	RTS	TxD+	TxD+	7
15	TxD#	TxD-	TxD-	3
16	CTS	RxD+	RxD+	8
17	+5V pull-up	+5V pull-up	+5V pull-up	4
18	NC	NC	NC	9
19	Ground	Ground	Ground	5
20	NC	NC	NC	—

Note: In full-duplex RS-485 operation the four signals [TxD+/TxD-] and [RxD+/RxD-] must be externally connected together by the user to form a single differential pair consisting of [TxD/RxD+] and [TxD/RxD-].

### COM5 and COM6 (J3)

The interface to COM5 and COM6 is provided by connector J3. VL-CBR-2001 connects to J3 and provides two DB-9M connectors. The pinouts for these connectors are shown below.

**Table 6: COM5 and COM6 Pinouts**

J3 Pin	RS-232	RS-422	RS-485	VL-CBR-2001 DB-9 COM5 Pin
1	NC	NC	NC	1
2	NC	NC	NC	6
3	RXD#	RxD-	RxD-	2
4	RTS	TxD+	TxD+	7
5	TXD#	TxD-	TxD-	3
6	CTS	RxD+	RxD+	8
7	+5V pull-up	+5V pull-up	+5V pull-up	4
8	NC	NC	NC	9
9	Ground	Ground	Ground	5
10	NC	NC	NC	—

J3 Pin	RS-232	RS-422	RS-485	VL-CBR-2001 DB-9 COM6 Pin
11	NC	NC	NC	1
12	NC	NC	NC	6
13	RXD#	RxD-	RxD-	2
14	RTS	TxD+	TxD+	7
15	TXD#	TxD-	TxD-	3
16	CTS	RxD+	RxD+	8
7	+5V pull-up	+5V pull-up	+5V pull-up	4
8	NC	NC	NC	9
9	Ground	Ground	Ground	5
10	NC	NC	NC	—

Note: In full-duplex RS-485 operation the four signals [TxD+/TxD-] and [RxD+/RxD-] must be externally connected together by the user to form a single differential pair consisting of [TxD/RxD+] and [TxD/RxD-].

## GPS and Antenna

GPS-enabled models of the VL-EPMs-U1 incorporate the Lassen iQ GPS receiver. The Lassen iQ is a full-featured, ultra-low power receiver suitable for a variety of embedded applications. The receiver outputs position, velocity, and time (PVT) data in the NMEA 0183 Version 3.0 ASCII protocol, the Trimble ASCII Interface Protocol, and the Trimble TSIP binary protocol.

The GPS receiver communicates with the VL-EPMs-U1 via COM3 and COM4.

See the [Lassen iQ Support Page](#) for documentation and support tools. Refer to the [Lassen iQ GPS Receiver System Designer Reference Manual](#) for GPS command details.

The GPS receiver is soldered onto the board at position J8 and the GPS-to-antenna lead is attached to connector J9. GPS power consumption is included in the EPMs-U1 power requirements.

**Note** The GPS receiver is ready to accept TSIP commands approximately 2.1 seconds after power-up. If a command is sent to the receiver within this 2.1 second window, the receiver will ignore the command. The GPS receiver will not respond to commands sent within the 2.1 second window and will discard any associated command data.

### ANTENNA CONNECTOR (J5)

A Trimble GPS antenna, VersaLogic part number VL-CBR-ANT02, is available for GPS-enabled models of the VL-EPMs-U1. The antenna has a 5-meter cable and male SMA connector.

### BATTERY BACK-UP

The GPS receiver option provides a battery for back-up (BBU) power to keep the module's RAM memory alive and to power the real-time clock when the receiver's prime power is turned off. RAM memory is used to store the GPS almanac, ephemeris, and last position. By using BBU power, time to first fix in a hot start scenario is reduced to 10 seconds (typical). Though not required, providing BBU power can reduce time to first fix.

If battery power is not present (by removing the jumper from V1), the receiver's power can be cycled off/on to force a system reset and a cold start. The receiver should be off for no less than 3 minutes to ensure that the RAM memory does not retain any old data due to the residual voltage from the power supply. To speed up the process, turn the receiver unit back on immediately and issue TSIP command 0x1E with the value 4B. This packet forces a cold start and clears the battery-backed RAM, eliminating the need to wait 3 minutes.

Estimated average power-off battery life is 10 years.

**Table 7: GPS Battery Power Requirements**

Signal	Voltage	Current
V <sub>CC</sub>	3.0 to 3.6	27 mA
Battery Back-up	2.5 to 3.6	20 $\mu$ A @ +3.3V, 25°C
Ground	0	—

## Port Configuration

The GPS receiver module has two I/O ports. The table below provides the default protocols and port configurations for the receiver, as delivered from the factory. TSIP IN/OUT is the default protocol on Port 1 and RTCM-IN and NMEA-OUT is the default protocol on Port 2.

**Table 8: Default Protocols and Port Configurations**

Port	Input Protocol	Default Setup	Output Protocol	Default Setup
1	TSIP	Baud Rate: 9600 Data Bits: 8 Parity: Odd Stop Bits: 1 No Flow Control	TSIP	Baud Rate: 9600 Data Bits: 8 Parity: Odd Stop Bits: 1 No Flow Control
2	RTCM	Baud Rate: 4800 Data Bits: 8 Parity: None Stop Bits: 1 No Flow Control	NMEA	Baud Rate: 4800 Data Bits: 8 Parity: None Stop Bits: 1 No Flow Control

The GPS receiver can also be configured to output TAIP messages. The standard port characteristics for TAIP are:

- Baud Rate: 4800
- Data Bits: 8
- Parity: None
- Stop Bits: 1
- Flow Control: None

Any standard serial communications program, such as Windows Hyper-Terminal or PROCOMM, can be used to view the NMEA or TAIP output messages. TSIP is a binary protocol and outputs raw binary serial data that cannot be read when using Windows Hyper-Terminal or PROCOMM. To view the output of the TSIP protocol in text format, use the Trimble Studio, iQ\_CHAT, or iQ\_Monitor programs downloadable from the [Trimble Lassen iQ support page](#).

The serial port driver in the iQ\_CHAT Tool Kit matches the Lassen iQ GPS receiver serial port characteristics. The TSIPPRNT program converts binary data logged with the iQ\_CHAT program into text that may be printed and displayed.

**Note** When using the TSIP protocol to change port assignments or settings, confirm that your changes do not affect the ability to communicate with the receiver (e.g., selecting the PC COM port settings that do not match the receiver's, or changing the output protocol to TSIP while not using iQ\_CHAT).

## COORDINATE SYSTEMS

Once the GPS receiver achieves its first fix, it is ready to commence output of position, velocity, and time information. This information is output over the serial communications channel in either the TSIP or NMEA protocol, as determined by the settings of the receiver. These protocols are defined in the Lassen iQ Reference Manual.

### TSIP Coordinate Systems

TSIP has the widest choice of coordinate systems. The output format is chosen by TSIP command 0x35. The output formats include the following:

- LLA position — Latitude, longitude, altitude (LLA) according to the WGS-84 ellipsoid. Altitude can be chosen to be height above ellipsoid (HAE) or height above mean sea level (MSL).
- ENU velocity — ENU velocity is the velocity in East, North, and Up coordinates. These coordinates are easily converted to speed and heading.
- ECEF position and velocity — ECEF position and velocity is Earth-Centered, Earth-Fixed frame is a Cartesian coordinate frame with its center at the earth's center, the z-axis through the North Pole, and the x-axis through longitude 0 degrees, latitude 0 degrees. Velocity is reported relative to the same axes.

There are also two time coordinate systems:

- GPS time — GPS time is determined by an ensemble of atomic clocks operated by the Department of Defense (DOD).
- UTC time — UTC time is the world standard maintained by an ensemble of atomic clocks operated by government organizations around the world. UTC time replaced Greenwich Mean Time (GMT ) as the world standard in 1986.

GPS time is steered relative to Coordinated Universal Time (UTC). GPS does not recognize leap seconds resulting in a situation where GPS time is currently 13 seconds ahead of UTC time. Time tags for most output messages can be in either UTC time or GPS time, as chosen by TSIP command 0x35.

## NMEA 0183

The NMEA 0183 protocol only supports LLA format and UTC time. Velocity is always described as horizontal speed and heading; vertical speed is not output.

## PERFORMANCE CHARACTERISTICS

### Update Rate

The GPS receiver computes and outputs position solutions once per second, on the second. NMEA outputs can be scheduled at a slower rate using TSIP command 0x7A. TAIP outputs may be controlled with TSIP packet 0x7E.

### Dynamic Limits

The dynamic operating limits for the GPS receiver are listed below. These operating limits assume that the GPS module is correctly operating and that the overall system is designed to operate under the same dynamic conditions.

**Table 9: GPS Receiver Operating Limits**

Operation	Limit
Acceleration	4g (39.2 m/s <sup>2</sup> )
Acceleration <sup>2</sup> (Jerk)	20 m/s <sup>3</sup>
Speed	500 m/s
Altitude	18,000m

**Note** The GPS Receiver firmware contains an algorithm that allows either the speed limit or altitude limit to be exceeded, but not both. This allows the receiver to be used in high altitude (research balloon) applications without a special factory configuration.

### Re-acquisition

Re-acquisition time for momentary signal blockages is typically under two seconds.

When a satellite signal is momentarily interrupted during normal operation, the receiver continues to search for the lost signal at the satellite's last known Doppler frequency. If the signal is available again within 15 seconds, the receiver will normally re-establish track within two seconds. If the lost signal is not re-acquired within 15 seconds, the receiver initiates a broader frequency search. The receiver will continue to search for the satellite until it falls below the elevation mask.

**START-UP**

The GPS receiver module is a complete 12-channel parallel tracking GPS receiver designed to operate with the L1 frequency, standard position service, Coarse Acquisition code. When connected to an external GPS antenna, the receiver contains all the circuitry necessary to automatically acquire GPS satellite signals, track up to 12 GPS satellites, and compute location, speed, heading, and time. The receiver will automatically begin to search for and track GPS satellite signals at power-up.

The performance of a GPS receiver at power-up is determined largely by the availability and accuracy of the satellite ephemeris data and the availability of a GPS system almanac.

The first time the receiver is powered-up, it is searching for satellites from a cold start (no almanac). While the receiver will begin to compute position solutions within the first two minutes, the receiver must continuously track satellites for approximately 15 minutes to download a complete almanac. This initialization process should not be interrupted. With a complete almanac and back-up power, the time to first fix can typically be shortened to less than 42 seconds. The receiver will respond to commands almost immediately after power-up.

## SUMIT-A Top Connector (J6)

The table below shows the SUMIT-A Top connections to the VL-EPMs-U1. Signals that are not connected are pass-through only. The +5V signals on this connector are available to power the VL-EPMs-U1. This connector is present on all models.

**Note:** SUMIT technology uses an automatic link alignment feature (also known as “lane shifting”) to eliminate the need for jumpers or switches to identify an expansion module’s position in the stack. Signals are not simply passed straight up from the bottom connector to the top on SUMIT modules. Links that are used by the expansion module are automatically selected, and the remaining unused signals are shifted down to the consumed link’s pins on the top connector for use by the next board. Both PCIe and USB signals are subject to auto-alignment. See [page 28 of the SUMIT Specification](#) for an explanation of this feature.

**Table 10: SUMIT-A Top Connector Pinout**

Pin	Signal Name	Function
1	+5V <sub>SB</sub>	+5V power standby
3	+3.3V	+3.3V power
5	+3.3V	+3.3V power
7	EXPCD_REQ#	ExpressCard request
9	EXPCD_PRSENT#	ExpressCard present
11	USB_OC#	USB overcurrent flag
13	Reserved	Pass-through
15	Reserved	Pass-through
17	Reserved	Pass-through
19	Reserved	Pass-through
21	+5V	+5V power
23	USB2+	USB2 data +
25	USB2-	USB2 data –
27	+5V	+5V power
29	USB1+	USB1 data +
31	USB1-	USB1 data –
33	+5V	+5V power
35	USB0+	USB0 data +
37	USB0-	USB0 data –
39	GND	Ground
41	A_PETp0	Link A, lane 0 transmit +
43	A_PETn0	Link A, lane 0 transmit –
45	GND	Ground
47	PERST#	Reset
49	WAKE#	Wake
51	+5V	+5V power

Pin	Signal Name	Function
2	+12V	+12V power
4	SMB/I2C_DATA	SMBus data
6	SMB/I2C_CLK	SMBus clock
8	SMB/I2C_ALERT#	SMBus interrupt line in
10	SPI/μWire_DO	SPI data out from master
12	SPI/μWire_DI	SPI data in to master
14	SPI/μWire_CLK	SPI clock
16	SPI/μWire_CS0#	SPI chip select 0
18	SPI/μWire_CS1#	SPI chip select 1
20	Reserved	Pass-through
22	Reserved	Pass-through
24	LPC_AD0	LPC line 0
26	LPC_AD1	LPC line 1
28	LPC_AD2	LPC line 2
30	LPC_AD3	LPC line 3
32	LPC_FRAME#	LPC frame
34	SERIRQ#	Serial IRQ legacy
36	LPC_PRSENT#/GND	LPC card present
38	CLK_33MHz	33 MHz clock out
40	GND	Ground
42	A_PERp0	Link A, lane 0 receive +
44	A_PERn0	Link A, lane 0 receive –
46	APRSNT#/GND	Link A card present
48	A_CLKp	Link A clock +
50	A_CLKn	Link A clock –
52	GND	Ground

## SUMIT-B Top Connector (J7)

The table below shows the SUMIT-B Top connections to the VL-EPMs-U1. Signals that are not connected are pass-through only. The +5V signals on this connector are available to power the VL-EPMs-U1. This connector is present on the C, D, G, and H models only. (See the SUMIT "lane shifting" note on page 23.)

**Table 11: SUMIT-B Top Connector Pinout**

Pin	Signal Name	Function
1	GND	Ground
3	B_PETp0	Link B, lane 0 transmit +
5	B_PETn0	Link B, lane 0 transmit –
7	GND	Ground
9	C_CLKp	Link C clock +
11	C_CLKn	Link C clock –
13	CPRSNT#/GND	Link C present
15	C_PETp0	Link C, lane 0 transmit +
17	C_PETn0	Link C, lane 0 transmit –
19	GND	Ground
21	C_PETp1	Link C, lane 1 transmit +
23	C_PETn1	Link C, lane 1 transmit –
25	GND	Ground
27	C_PETp2	Link C, lane 2 transmit +
29	C_PETn2	Link C, lane 2 transmit –
31	GND	Ground
33	C_PETp3	Link C, lane 3 transmit +
35	C_PETn3	Link C, lane 3 transmit –
37	GND	Ground
39	PERST#	Reset
41	Reserved	Pass-through
43	+5V	+5V power
45	+5V	+5V power
47	+5V	+5V power
49	+5V	+5V power
51	+5V	+5V power

Pin	Signal Name	Function
2	GND	Ground
4	B_PERp0	Link B, lane 0 receive +
6	B_PERn0	Link B, lane 0 receive –
8	BPRSNT#/GND	Link B present
10	B_CLKp	Link B clock +
12	B_CLKn	Link B clock –
14	GND	Ground
16	C_PERp0	Link C, lane 0 receive +
18	C_PERn0	Link C, lane 0 receive –
20	GND	Ground
22	C_PERp1	Link C, lane 1 receive +
24	C_PERn1	Link C, lane 1 receive –
26	GND	Ground
28	C_PERp2	Link C, lane 2 receive +
30	C_PERn2	Link C, lane 2 receive –
32	GND	Ground
34	C_PERp3	Link C, lane 3 receive +
36	C_PERn3	Link C, lane 3 receive –
38	GND	Ground
40	WAKE#	Wake
42	Reserved	Pass-through
44	Reserved	Pass-through
46	+3.3V	+3.3V power
48	+3.3V	+3.3V power
50	+3.3V	+3.3V power
52	+5V <sub>SB</sub>	+5V standby power

## PC/104 (ISA) Connector (J10)

The PC/104 (ISA) connector is a pass-through connector only. This connector is present only on the VL-EPMs-U1C, D, G, and H. The +5V and ground signals on this connector are available to power the VL-EPMs-U1.

## SUMIT-B Bottom Connector (J11)

The table below shows the SUMIT-B Bottom connections to the VL-EPMs-U1. Signals that are not connected are pass-through only. The +5V and ground signals on this connector are available to power the VL-EPMs-U1. This connector is present on the C, D, G, and H models only. (See the SUMIT "lane shifting" note on page 23.)

Table 12: SUMIT-B Bottom Connector Pinout

Pin	Signal Name	Function
1	GND	Ground
3	B_PETp0	Link B, lane 0 transmit +
5	B_PETn0	Link B, lane 0 transmit –
7	GND	Ground
9	C_CLKp	Link C clock +
11	C_CLKn	Link C clock –
13	CPRSNT#/GND	Link C card present
15	C_PETp0	Link C, lane 0 transmit +
17	C_PETn0	Link C, lane 0 transmit –
19	GND	Ground
21	C_PETp1	Link C, lane 1 transmit +
23	C_PETn1	Link C, lane 1 transmit –
25	GND D	Ground
27	C_PETp2	Link C, lane 2 transmit +
29	C_PETn2	Link C, lane 2 transmit –
31	GND	Ground
33	C_PETp3	Link C, lane 3 transmit +
35	C_PETn3	Link C, lane 3 transmit –
37	GND	Ground
39	PERST#	Reset
41	Reserved	Pass-through
43	+5V	+5V power
45	+5V	+5V power
47	+5V	+5V power
49	+5V	+5V power
51	+5V	+5V power

Pin	Signal Name	Function
2	GND	Ground
4	B_PERp0	Link B, lane 0 receive +
6	B_PERn0	Link B, lane 0 receive –
8	BPRSNT#/GND	Link B present
10	B_CLKp	Link B clock +
12	B_CLKn	Link B clock –
14	GND	Ground
16	C_PERp0	Link C, lane 0 receive +
18	C_PERn0	Link C, lane 0 receive –
20	GND	Ground
22	C_PERp1	Link C, lane 1 receive +
24	C_PERn1	Link C, lane 1 receive –
26	GND	Ground
28	C_PERp2	Link C, lane 2 receive +
30	C_PERn2	Link C, lane 2 receive –
32	GND	Ground
34	C_PERp3	Link C, lane 3 receive +
36	C_PERn3	Link C, lane 3 receive –
38	GND	Ground
40	WAKE#	Wake
42	Reserved	Pass-through
44	Reserved	Pass-through
46	+3.3V	+3.3V power
48	+3.3V	+3.3V power
50	+3.3V	+3.3V power
52	+5V <sub>SB</sub>	+5V standby power

## SUMIT-A Bottom Connector (J12)

The table below shows the SUMIT-A Bottom connections to the VL-EPMs-U1. Signals that are not connected are pass-through only. The +5V and ground signals on this connector are available to power the VL-EPMs-U1. This connector is present on all models. (See the SUMIT "lane shifting" note on page 23.)

Table 13: SUMIT-A Bottom Connector Pinout

Pin	Signal Name	Function
1	+5V <sub>SB</sub>	+5V power standby
3	+3.3V	+3.3V power
5	+3.3V	+3.3V power
7	EXPCD_REQ#	ExpressCard request
9	EXPCD_PRSNT#	ExpressCard present
11	USB_OC#0/1	USB0-1 overcurrent flag
13	Reserved	Pass-through
15	Reserved	Pass-through
17	Reserved	Pass-through
19	Reserved	Pass-through
21	+5V	+5V power
23	USB2+	USB2 data +
25	USB2-	USB2 data -
27	+5V	+5V power
29	USB1+	USB1 data +
31	USB1-	USB1 data -
33	+5V	+5V power
35	USB0+	USB0 data +
37	USB0-	USB0 data -
39	GND	Ground
41	A_PETp0	Link A, lane 0 transmit +
43	A_PETn0	Link A, lane 0 transmit -
45	GND	Ground
47	PERST#	Reset
49	WAKE#	Wake
51	+5V	+5V power

Pin	Signal Name	Function
2	+12V	+12V power
4	SMB/I2C_DATA	SMBus data
6	SMB/I2C_CLK	SMBus clock
8	SMB/I2C_ALERT#	SMBus interrupt line in
10	SPI/uWire_DO	SPI data out from master
12	SPI/uWire_DI	SPI data in to master
14	SPI/uWire_CLK	SPI clock
16	SPI/uWire_CS0#	SPI chip select 0
18	SPI/uWire_CS1#	SPI chip select 1
20	Reserved	Pass-through
22	Reserved	Pass-through
24	LPC_AD0	LPC line 0
26	LPC_AD1	LPC line 1
28	LPC_AD2	LPC line 2
30	LPC_AD3	LPC line 3
32	LPC_FRAME#	LPC frame
34	SERIRQ#	Serial IRQ legacy
36	LPC_PRSNT#/GND	LPC card present
38	CLK_33MHz	33 MHz clock out
40	GND	Ground
42	A_PERp0	Link A, lane 0 receive +
44	A_PERn0	Link A, lane 0 receive -
46	APRSNT#/GND	Link A card present
48	A_CLKp	Link A clock +
50	A_CLKn	Link A clock -
52	GND	Ground

## Appendix A – References

---



SUMIT Interface	<a href="#">SUMIT Specification</a>
PC/104 Interface	<a href="#">PC/104 Specification</a>
Lassen iQ GPS Receiver	<a href="#">Lassen iQ GPS Receiver System Designer Reference Manual</a>
General PC Documentation <i>The Programmer's PC Sourcebook</i>	<a href="#">Amazon.com</a>
General PC Documentation <i>The Undocumented PC</i>	<a href="#">Amazon.com</a>