

Reference Manual

DOC. REV. 7/21/2011

VL-EPMp-34 (Wildcat)

Intel Core 2 Duo Based SBC
with Gigabit Ethernet, SATA,
PC/104-Plus, Video, Audio, and
SPX



VERSALOGIC
CORPORATION



WWW.VERSALOGIC.COM

4211 West 11th Ave.
Eugene, OR 97402
(541) 485-8575
Fax (541) 485-5712

Copyright © 2011 VersaLogic Corp. All rights reserved.

Notice:

Although every effort has been made to ensure this document is error-free, VersaLogic makes no representations or warranties with respect to this product and specifically disclaims any implied warranties of merchantability or fitness for any particular purpose.

VersaLogic reserves the right to revise this product and associated documentation at any time without obligation to notify anyone of such changes.

PC/104 and the PC/104 logo are trademarks of the PC/104 Consortium.

Product Release Notes

Rev 2.00 – Minor changes to improve manufacturability. No customer impact.

Rev 1.00 – Initial commercial release.

Support Page

The VL-EPMp-34 support page, at <http://www.versalogic.com/private/wildcatsupport.asp>, contains additional information and resources for this product including:

- Reference Manual (PDF format)
- Operating system information and software drivers
- Data sheets and manufacturers' links for chips used in this product
- Photograph of the circuit board
- BIOS information and upgrades
- Utility routines and benchmark software

Note: This is a private page for VL-EPMp-34 users that can be accessed only by entering this address directly. It cannot be reached from the VersaLogic homepage.

The VersaTech KnowledgeBase is an invaluable resource for resolving technical issues with your VersaLogic product.

[VersaTech KnowledgeBase](#)

Contents

| | |
|---|-----------|
| Introduction | 1 |
| Description..... | 1 |
| Features and Construction | 1 |
| Technical Specifications | 2 |
| VL-EPMp-34 Block Diagram..... | 3 |
| Thermal Considerations | 4 |
| CPU Die Temperature..... | 4 |
| Model Differences | 4 |
| RoHS Compliance | 4 |
| About RoHS..... | 4 |
| Warnings..... | 5 |
| Electrostatic Discharge | 5 |
| Lithium Battery..... | 5 |
| Handling Care..... | 5 |
| Technical Support..... | 6 |
| Repair Service..... | 6 |
| Configuration and Setup | 7 |
| Initial Configuration | 7 |
| Basic Setup | 7 |
| CMOS Setup..... | 10 |
| Operating System Installation..... | 15 |
| Physical Details..... | 16 |
| Dimensions and Mounting..... | 16 |
| CBR-3406 Dimensions | 17 |
| Hardware Assembly..... | 18 |
| Stack Arrangement Example | 18 |
| External Connectors..... | 19 |
| VL-EPMp-34 Connector Locations – Top | 19 |
| VL-EPMp-34 Connector Locations – Bottom..... | 20 |
| VL-EPMp-34 Connector Functions and Interface Cables | 21 |
| Connector Locations – VL-CBR-3406 | 22 |
| CBR-3406 Connector Functions and Mating Connectors | 22 |
| Jumper Blocks..... | 23 |
| Jumpers As-Shipped Configuration..... | 23 |
| Jumper Summary | 24 |
| System Features | 25 |
| Power Supply | 25 |
| Power Connectors..... | 25 |
| Power Requirements | 26 |
| CPU..... | 26 |
| System RAM..... | 26 |

| | |
|--|-----------|
| Memory..... | 26 |
| CMOS RAM..... | 26 |
| Clearing CMOS RAM..... | 26 |
| CMOS Setup Defaults..... | 27 |
| Default CMOS RAM Setup Values..... | 27 |
| Primary and Backup BIOS..... | 27 |
| Real Time Clock..... | 27 |
| Setting the Clock..... | 27 |
| Watchdog Timer..... | 28 |
| Fan/Tachometer Monitor..... | 28 |
| Fan/Tach IRQ Code Example..... | 28 |
| Interfaces and Connectors..... | 30 |
| PCI-104 Expansion Bus (JN1)..... | 30 |
| I/O Connector (JN2)..... | 30 |
| Serial Port..... | 31 |
| USB Interface..... | 31 |
| Programmable LED..... | 32 |
| HD LED..... | 32 |
| Internal Speaker..... | 32 |
| Lithium Battery..... | 32 |
| Pushbutton Reset..... | 33 |
| SATA Ports (JN5)..... | 33 |
| Video Interface..... | 34 |
| Configuration..... | 34 |
| SVGA Output Connector (JN11)..... | 34 |
| LVDS Flat Panel Display Connector (JN9)..... | 35 |
| Compatible LVDS Panel Displays..... | 36 |
| Console Redirection..... | 36 |
| Ethernet Interface (JN6)..... | 37 |
| Ethernet Connector..... | 37 |
| Ethernet Status LEDs..... | 37 |
| Digital Audio (JN3)..... | 38 |
| MiniBlade (JN7)..... | 38 |
| SPX™ Expansion Bus (JN4)..... | 39 |
| VersaLogic SPX Expansion Modules..... | 39 |
| SPI Registers..... | 40 |
| Interrupt Configuration..... | 43 |
| Special Registers..... | 44 |
| Product Code Register..... | 44 |
| Revision Level Register..... | 45 |
| Special Control Register..... | 46 |
| Watchdog Hold Register..... | 47 |
| Fan/Tachometer Control Register..... | 47 |
| Appendix A – References..... | 48 |

Description

FEATURES AND CONSTRUCTION

The VL-EPMp-34 is a feature-packed single board computer (SBC) designed for OEM control projects requiring fast processing and designed-in reliability and longevity (product lifespan). Its features include:

- Intel Core 2 Duo processor, 2.26 GHz, 1066 MHz FSB, 6 MB cache
- Up to 4 GB DDR3 SODIMM socket
- USB MiniBlade socket
- 10BaseT / 100BaseTX / 1000BaseT Ethernet interface
- Intel GMA 4500 MHD graphics core
- Simultaneous VGA and LVDS outputs
- PC/104-*Plus* (PCI) expansion
- Two SATA 3 Gb/s ports
- Four USB 2.0 ports for keyboard, mouse, floppy, and other devices
- TVS devices for ESD protection
- Watchdog timer
- One RS-232/422/485 serial port
- Vcc sensing reset circuit
- PC/104-compliant
- Field upgradeable BIOS with OEM enhancements
- External HD Audio compatible
- Customizing available
- SPX interface supports up to four (external) SPI devices either of user design or any of the SPX™ series of expansion boards, with clock frequencies from 1-8MHz

The VL-EPMp-34 is a PCI-104-compliant single board computer with an Intel Core 2 Duo processor. The board is compatible with popular operating systems such as Windows, Windows Embedded, QNX, VxWorks and Linux.

The VL-EPMp-34 features high reliability design and construction, including voltage sensing reset circuits and current limiting external power rails.

VL-EPMp-34 boards are subjected to 100% functional testing and are backed by a limited two-year warranty. Careful parts sourcing and US-based technical support ensure the highest possible quality, reliability, service and product longevity for this exceptional SBC.

Additional I/O expansion is available through the high-speed PC/104-*Plus* (PCI) connector. The VL-EPMp-34 is equipped with a multifunction utility cable, VL-CBR-3406 (breakout board), that provides standard I/O interfaces, including one serial port, four USB ports, two LEDs, and a pushbutton reset, among others.

Technical Specifications

Specifications are typical at 25°C with 5.0V supply unless otherwise noted.

Board Size:

3.55" x 3.775" (PC/104 standard) with connector overhangs in designated connector areas

Storage Temperature:

-40° C to 85° C

Operating Temperature: *(with Windows XP running with both CPU cores at 1.2GHz/95% utilization with active 2D and 3D video)*

VL-EPMp-34S: 0° C to +60° C free air, no airflow

VL-EPMp-34E: -40° C to +85° C free air

Power Requirements: *(with 1 GB system DDR3 SO-DIMM, keyboard and mouse, Running Windows XP)*

5V ± 5% @ 1.8A idle (6.1A max.)

+3.3V or ± 12V may be required by some expansion modules

System Reset:

V_{cc} sensing, resets below 4.70V typ.

DRAM:

Up to 4 GB, DDR3 SODIMM, 800 MHz PC3-6400 or 1067 MHz PC3-8500

Video Interface:

Intel GMA 4500 MHD graphics core

Analog output for VGA

LVDS output for TFT FPDs

Up to 1280 x 1024 (24 bits)

SATA Interface:

Two SATA 3 Gb/s ports

Flash Interface:

One MiniBlade socket, supports USB only

Ethernet Interface:

PCIe based 82574IT supporting autodetect

10BaseT / 100BaseTX / 1000BaseT

Serial Port:

RS-232/422/485, 16C550 compatible, 4-wire (only CTS and RTS handshaking)

BIOS:

Phoenix Embedded BIOS© with StrongFrame® Technology and OEM enhancements
Field-upgradeable with Flash BIOS Update Utility

Bus Speed:

PC/104-Plus (PCI): 33MHz

Compatibility:

Embedded-PCI (PCI-104) – full compliance, 3.3V signaling

Weight:

0.230 kg (0.507 lb)

Specifications are subject to change without notice.

VL-EPMp-34 Block Diagram

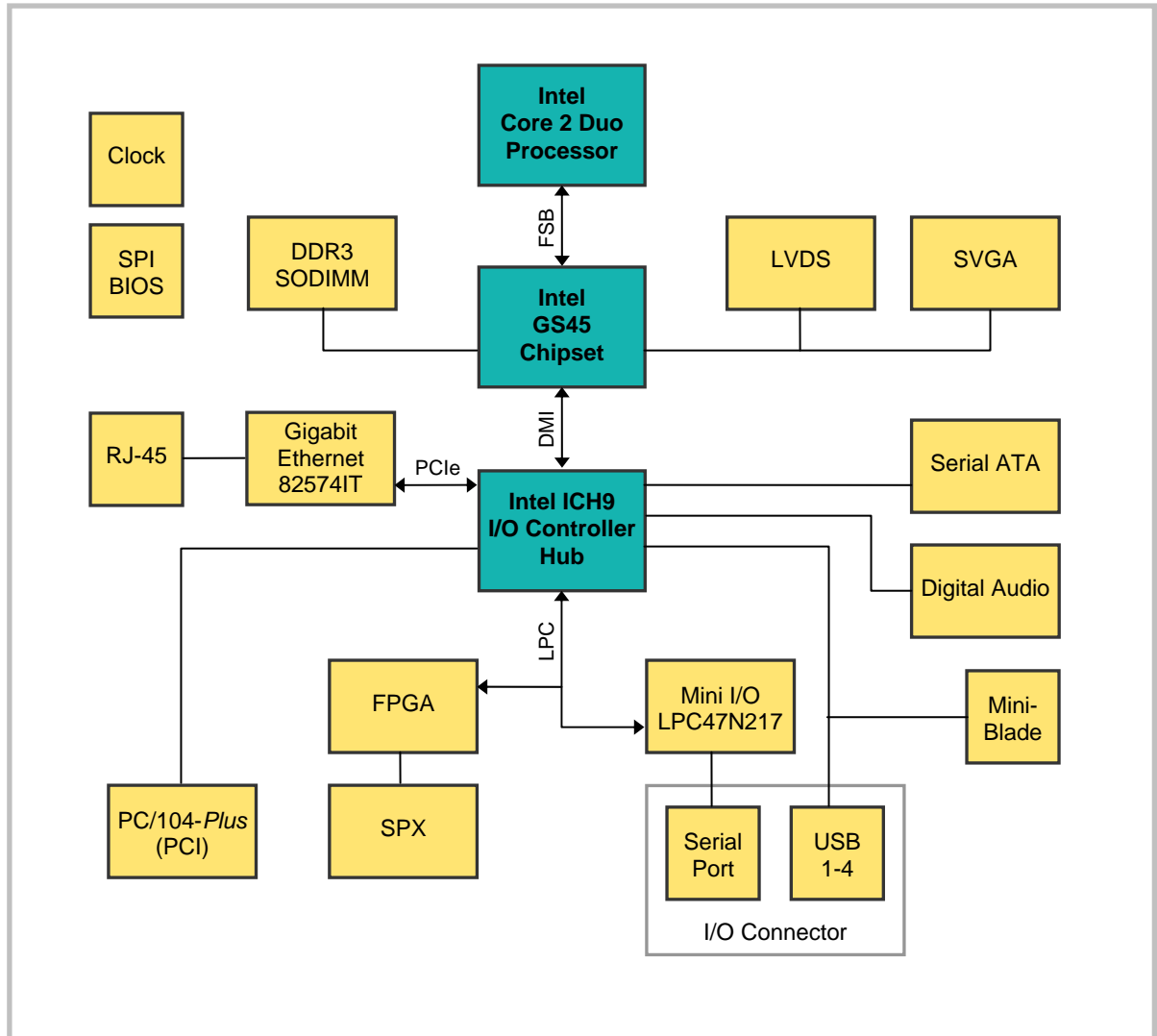

Figure 1. System Block Diagram

Thermal Considerations

CPU DIE TEMPERATURE

The CPU die temperature is affected by numerous conditions, such as CPU utilization, CPU speed, ambient air temperature, air flow, thermal effects of adjacent circuit boards, external heat sources, and many others.

The CPU is protected from over temperature conditions by several mechanisms.

The CPU will automatically slow down by 50% whenever its die temperature exceeds 105° C. When the temperature falls back below 105° C, the CPU resumes full speed operation.

As a failsafe, if the CPU die temperature climbs above 115° C, the CPU will turn itself off to prevent damage to the chip.

MODEL DIFFERENCES

VersaLogic offers both standard and extended temperature models of the VL-EPMp-34. The basic operating temperature specification for both models is shown below.

- VL-EPMp-34S: 0° C to +60° C free air, no airflow
- VL-EPMp-34E: -40° C to +85° C free air

To reliably function at extreme temperatures the extended temperature model specifications deviate from the standard model in the following ways:

- The DRAM interface is slowed. PC3-6400 memory runs at 600 MHz. PC3-8500 memory runs at 800 MHz.
- The DRAM refresh rates are doubled.
- The Front Side Bus speed is reduced to 800 MHz.
- Maximum processor speed is limited to 1200 MHz.
- The graphics core is limited to 400 MHz.

RoHS Compliance

The VL-EPMp-34 is RoHS-compliant.

ABOUT ROHS

In 2003, the European Union issued Directive 2002/95/EC regarding the Restriction of the use of certain Hazardous Substances (RoHS) in electrical and electronic equipment.

The RoHS directive requires producers of electrical and electronic equipment to reduce to acceptable levels the presence of six environmentally sensitive substances: lead, mercury, cadmium, hexavalent chromium, and the presence of polybrominated biphenyls (PBB) and polybrominated diphenyl ethers (PBDE) flame retardants, in certain electrical and electronic products sold in the European Union (EU) beginning July 1, 2006.

VersaLogic Corporation is committed to supporting customers with high-quality products and services meeting the European Union's RoHS directive.

Warnings

ELECTROSTATIC DISCHARGE

Warning! Electrostatic discharge (ESD) can damage circuit boards, disk drives and other components. The circuit board must only be handled at an ESD workstation. If an approved station is not available, some measure of protection can be provided by wearing a grounded antistatic wrist strap. Keep all plastic away from the board, and do not slide the board over any surface.

After removing the board from its protective wrapper, place the board on a grounded, static-free surface, component side up. Use an antistatic foam pad if available.

The board should also be protected inside a closed metallic anti-static envelope during shipment or storage.

Note: The exterior coating on some metallic antistatic bags is sufficiently conductive to cause excessive battery drain if the bag comes in contact with the battery.

LITHIUM BATTERY

Warning! To prevent shorting, premature failure or damage to the lithium battery, do not place the board on a conductive surface such as metal, black conductive foam or the outside surface of a metalized ESD protective pouch. The lithium battery may explode if mistreated. Do not recharge, disassemble or dispose of in fire. Dispose of used batteries promptly and in an environmentally suitable manner.

HANDLING CARE

Warning! Care must be taken when handling the board not to touch the exposed circuitry with your fingers. Though it will not damage the circuitry, it is possible that small amounts of oil or perspiration on the skin could have enough conductivity to cause the contents of CMOS RAM to become corrupted through careless handling, resulting in CMOS resetting to factory defaults.

Technical Support

If you are unable to solve a problem after reading this manual please visit the VL-EPMp-34 product support web page below. The support page provides links to component datasheets, device drivers, and BIOS and FPGA code updates.

VL-EPMp-34 Support Page

<http://www.versalogic.com/private/wildcatsupport.asp>

The VersaTech KnowledgeBase also contains a wealth of technical information about VersaLogic products, along with product advisories. Click the link below to see all KnowledgeBase articles related to the VL-EPMp-34.

[VersaTech KnowledgeBase](#)

If you have further questions, contact VersaLogic Technical Support at (541) 485-8575. VersaLogic support engineers are also available via e-mail at Support@VersaLogic.com.

REPAIR SERVICE

If your product requires service, you must obtain a Returned Material Authorization (RMA) number by calling (541) 485-8575. Please provide the following information:

- Your name, the name of your company, your phone number, and e-mail address
- The name of a technician or engineer that can be contacted if any questions arise
- Quantity of items being returned
- The model and serial number (barcode) of each item
- A detailed description of the problem
- Steps you have taken to resolve or recreate the problem
- The return shipping address

Warranty Repair All parts and labor charges are covered, including return shipping charges for UPS Ground delivery to United States addresses.

Non-warranty Repair All non-warranty repairs are subject to diagnosis and labor charges, parts charges and return shipping fees. Please specify the shipping method you prefer and provide a purchase order number for invoicing the repair.

Note: Please mark the RMA number clearly on the outside of the box before returning.

Initial Configuration

The following components are recommended for a typical development system.

- VL-EPMp-34 computer
- 204-pin SO-DIMM (memory module): DDR3-800 or DDR3-1066
- ATX power supply
- SVGA video monitor
- USB keyboard
- USB mouse
- SATA hard drive
- USB CD-ROM drive

The following VersaLogic cables are recommended.

- CBR-1201 – Video adapter cable
- CBR-3406 – Utility I/O cable and breakout board
- CBR-0701 – SATA data cable
- CBR-1008 – Power adapter cable

You will also need a Windows (or other OS) installation CD.

Basic Setup

The following steps outline the procedure for setting up a typical development system. The VL-EPMp-34 should be handled at an ESD workstation or while wearing a grounded antistatic wrist strap.

Before you begin, unpack the VL-EPMp-34 and accessories. Verify that you received all the items you ordered. Inspect the system visually for any damaged that may have occurred in shipping. Contact Support@VersaLogic.com immediately if any items are damaged or missing.

Gather all the peripheral devices you plan to attach to the VL-EPMp-34 and their interface and power cables.

It is recommended that you attach standoffs to the board (see Hardware Assembly) to stabilize the board and make it easier to work with.

Figure 2 shows a typical start-up configuration.

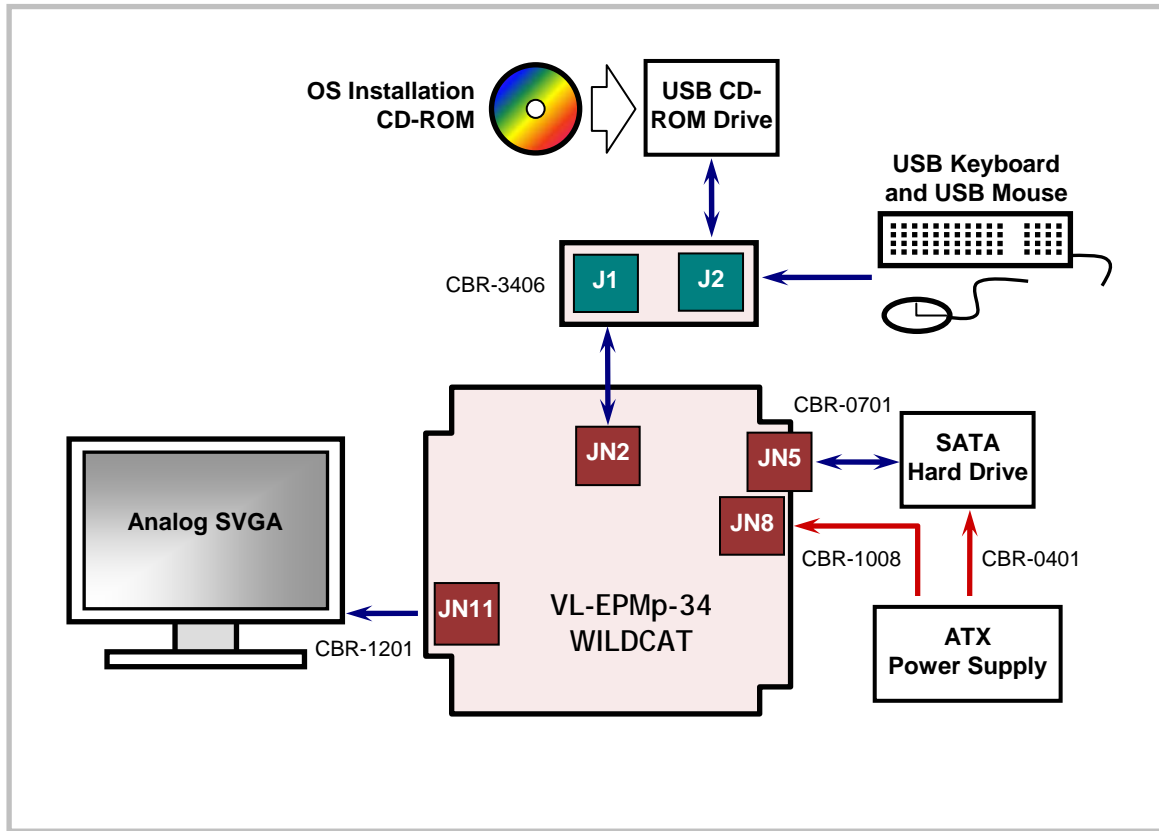

Figure 2. Typical Start-up Configuration

1. Install Memory

- Insert the DRAM module into SO-DIMM socket JN13 on the bottom of the board and latch it into place.

2. Attach Power

- Plug the power adapter cable VL-CBR-1008 into socket JN8. Attach the motherboard connector of the ATX power supply to the adapter.

3. Attach Cables and Peripherals

- Plug the video adapter cable VL-CBR-1201 into socket JN11. Attach the video monitor interface cable to the video adapter.
- Plug the breakout cable VL-CBR-3406 into socket JN2. (The cable and board are shipped attached.)
- Plug a USB keyboard, USB mouse, and USB CD-ROM drive into socket J2 of the breakout board.
- Plug the SATA hard drive data cable VL-CBR-0701 into socket JN5 (top or bottom) and attach a hard drive to the cable.
- Attach an ATX power cable to the SATA hard drive using the VL-CBR-0401 SATA power adapter cable.

4. Review Configuration

- Before you power up the system, double check all the connections. Make sure all cables are oriented correctly and that adequate power will be supplied to the VL-EPMp-34 and peripheral devices.

5. Power On

- Turn on the ATX power supply and the video monitor. If the system is correctly configured, a video signal should be present.

6. Install Operating System

- Install the operating system according to the instructions provided by the OS manufacturer. (See Operating System Installation.)

Note: If you intend to operate the VL-EPMp-34 under Windows XP or Windows XP Embedded, be sure to use Service Pack 2 (SP2) for full support of the latest hardware features.

CMOS Setup

The default CMOS Setup parameters for the VL-EPMp-34S are shown below. The factory default date will correspond to the BIOS build date. Some values may vary depending on the configuration of your VL-EPMp-34. See VersaLogic KnowledgeBase article [VT1639 – VL-EPMp-34 Wildcat CMOS Setup Reference](#) for more information about these parameters and variations for the VL-EPMp-34E.

Main Menu

| | | |
|---|--|--|
| <pre> System Summary ----- Phoenix[R] System BIOS VersaLogic Version 6.5.103 Core Version EB(SF).005 BIOS Build Date 04/21/11 System BIOS Size 128KB CPM/CSPM/BPM Modules P7C7, GM45, EPMp34 StrongFrame(R) Technology, Firmbase(R) Technology Processor (CPU) Intel(R) Core(TM)2 Duo CPU P9300 @ 2.26GHz Processor Count 2 System Memory (RAM) Low Memory (KB) 626 Extended Memory (KB) 1004352 Memory Above 4GB 0 Real Time Clock (RTC) RTC Date [04/21/2011] RTC Time [01:04:15] </pre> | | <pre> Use TAB to switch between month, day and year. Use digits and BKSP to change field. </pre> |
|---|--|--|

Exit Menu

| | | |
|---|--|---|
| <pre> Save, Restore, and Exit Setup ----- Save Settings and Restart [Enter] Exit Setup Without Saving Changes [Enter] Reload Factory-Defaults and Restart [Enter] Reload Custom-Defaults and Restart [Enter] </pre> | | <pre> Press ENTER to save changes and reboot system. </pre> |
|---|--|---|

Boot Menu

| | |
|--|---|
| <p>System Boot Configuration</p> <p>-----</p> <p>Boot Device Prioritization (BBS) 0 [SATA JN5_Top] 1 [SATA JN5_Bot] 2 [None]</p> <p>Initialization Policy [All Devices]</p> <p>IDE Drive Configuration</p> <p>ICH ATA Controller Configuration</p> <p>-----</p> <p>SATA Controller [Native Mode]</p> | <p>Select initialization and boot priority for all devices.</p> <p>Backspace deletes selection. Space bar, + and - change selections.</p> |
|--|---|

POST Menu

| | |
|---|---|
| <p>POST Memory Tests</p> <p>-----</p> <p>Low Memory Standard Test [Enabled] Low Memory Exhaustive Test [Disabled] High Memory Standard Test [Disabled] High Memory Exhaustive Test [Disabled] Click During Memory Test [Enabled] Clear Memory During Test [Disabled]</p> <p>POST Error Control</p> <p>-----</p> <p>POST User Interface</p> <p>-----</p> <p>POST Display Messages [Enabled] POST Operator Prompt [Enabled] POST Display PCI Devices [Enabled]</p> <p>POST Debugging</p> <p>-----</p> <p>POST Slow Reboot Cycle [Disabled] POST Fast Reboot Cycle [Disabled]</p> <p>Device Initialization</p> <p>-----</p> <p>POST Floppy Seek [Disabled] POST Hard Disk Seek [Enabled]</p> | <p>Enable basic memory confidence test below 1MB during POST.</p> |
|---|---|

SIO Menu

| | | |
|---|-------------------|---|
| BIOS Super I/O Configuration | | RS-422/485/232-4wire on JN2, CBR-3406. |
| SMSC LPC47N217 (North board) Devices | | |
| Serial Port 5 | [Enabled] | |
| Address | [220h] | |
| IRQ | [IRQ 5] | |
| Mode | [RS-232 (4-wire)] | |
| SMSC SCH3114 (South board) Devices | | |
| Daniels board not installed. | | |

Features Menu

| | | |
|---|------------|--|
| BIOS Feature Configuration | | Enable to initialize APICs and use them in an emulated PIC mode. If you wish to use full-APIC mode, this must be set AND either ACPI or MP must be enabled. DO NOT CHANGE AFTER OS INSTALL. |
| Interrupt Processing | [Use APIC] | |
| MP Tables (non ACPI OSes) | [Enabled] | |
| Quick Boot | [Enabled] | |
| ACPI | [Enabled] | |
| POST Memory Manager | [Enabled] | |
| System Management BIOS | [Enabled] | |
| Splash Screen | [Disabled] | |
| Console Redirection | | |
| Use Console Assignments Below [On Remote User Detect] | | |
| POST Console | [COM1] | |
| Legacy Free Option | | |
| Legacy-Free | [Disabled] | |
| ACPI FACP 8042 Flag | [Disabled] | |
| Plug-n-Play (PnP) Configuration | | |
| Plug-n-Play | [Enabled] | |

Firmware Menu

| Features Enabled by Firmware[R] Technology | | Enable to support USB keyboard and mouse |
|--|------------|--|
| Legacy USB | [Enabled] | |
| USB Boot | [Enabled] | |
| EHCI/USB 2.0 | [Enabled] | |
| Firmware User Shell | [Enabled] | |
| Basic Firmware[R] Technology Configuration | | |
| Firmware Technology | [Enabled] | |
| Periodic SMI | [Enabled] | |
| Firmware Debug Log | [None] | |
| Firmware System Console | [None] | |
| Firmware Shell on Serial Port | [None] | |
| Firmware[R] Technology Foreground IRQ Monitoring | | |
| IRQ0 (Timer) | [Disabled] | |
| IRQ1 (Keyboard) | [Disabled] | |
| IRQ2 (Cascade) | [Disabled] | |
| IRQ3 (COM2/COM4) | [Disabled] | |
| IRQ4 (COM1/COM3) | [Disabled] | |
| IRQ5 (LPT2) | [Disabled] | |
| IRQ6 (Floppy) | [Disabled] | |
| IRQ7 (LPT1) | [Disabled] | |
| IRQ8 (RTC) | [Disabled] | |
| IRQ9 (PCI/SCI) | [Disabled] | |
| IRQ10 (PCI) | [Disabled] | |
| IRQ11 (PCI) | [Disabled] | |
| IRQ12 (Mouse) | [Disabled] | |
| IRQ13 (NPX) | [Disabled] | |
| IRQ14 (IDE) | [Disabled] | |
| IRQ15 (IDE) | [Disabled] | |

Misc Menu

| Cache Control | | Enable to allow CPU caching to operate. |
|----------------------|------------|---|
| System Cache | [Enabled] | |
| Keyboard Control | | |
| Keyboard Numlock LED | [Disabled] | |
| Typematic Rate | [30/sec] | |
| Typematic Delay | [250ms] | |

Board Menu

| | | |
|------------------------------------|------------|----------------------------------|
| Misc Control | | Daniels board presence override. |
| Daniels Override | [Disabled] | |
| FPGA base I/O address | [0xCA0] | |
| ISA Bus | [Enabled] | |
| 82574 Ethernet | [Enabled] | |
| PCI Interrupt Configuration | | |
| PCI INT A routing | [IRQ 11] | |
| PCI INT B routing | [IRQ 11] | |
| PCI INT C routing | [IRQ 11] | |
| PCI INT D routing | [IRQ 9] | |
| PCI INT E routing | [IRQ 9] | |
| PCI INT F routing | [IRQ 9] | |
| PCI INT G routing | [IRQ 9] | |
| PCI INT H routing | [IRQ 9] | |

Video Menu

| | | |
|-------------------------------------|------------|---|
| Display Device Configuration | | Select video boot display. Some modes may require a different Video BIOS support. |
| Video Boot Display | [CRT] | |
| LCD Flat Panel Type | [1024x768] | |
| Panel Fitting | [Default] | |
| Video Frame Buffer Size | [32MB] | |

Chipset Menu

| | | |
|-----------------------------------|------------|---|
| UHCI #6 Remapping | [Enabled] | Remap UHCI controller #6 from Dev1A:Func2 to Dev1D:Func3. |
| North Bridge Configuration | | |
| Memory Bandwidth Throttling | [Enabled] | |
| TM Lock | [Disabled] | |
| TS on DIMM | [Enabled] | |
| TS on Board | [Disabled] | |

AdvancedCPU Menu

| | | |
|--|------------|-----------------------|
| CPU Information | | Enable |
| ----- | | Geyserville/Speedste- |
| CPU Model and Stepping: | 1658 | p. |
| CPU Microcode Version: | 2567 | |
| On-Die Thermal Sensor, *C to Overheat: | 74 | |
| CPU Configuration | | |
| ----- | | |
| Board is standard temperature | | |
| P7 Geyserville/Speedstep | [Enabled] | |
| SpeedStep Manual Speed (ET) | [1200 MHz] | |
| SpeedStep Lock | [Enabled] | |
| Dynamic FSB | [Enabled] | |
| Intel VT | [Disabled] | |
| Microcode Update | [Enabled] | |
| C1E | [Disabled] | |
| C2E | [Enabled] | |
| C4E | [Enabled] | |
| Core Multi-Processing | [Enabled] | |

Note: Due to changes and improvements in the system BIOS, the information on your monitor may differ from that shown above.

Operating System Installation

The standard PC architecture used on the VL-EPMp-34 makes the installation and use of most of the standard x86 processor-based operating systems very simple. The operating systems listed on the [VersaLogic OS Compatibility Chart](#) use the standard installation procedures provided by the maker of the OS. Special optimized hardware drivers for a particular operating system, or a link to the drivers, are available at the VL-EPMp-34 Product Support web page at <http://www.versalogic.com/private/wildcatsupport.asp>.

Dimensions and Mounting

The VL-EPMp-34 complies with all PCI-104 standards. Dimensions are given below to help with pre-production planning and layout.

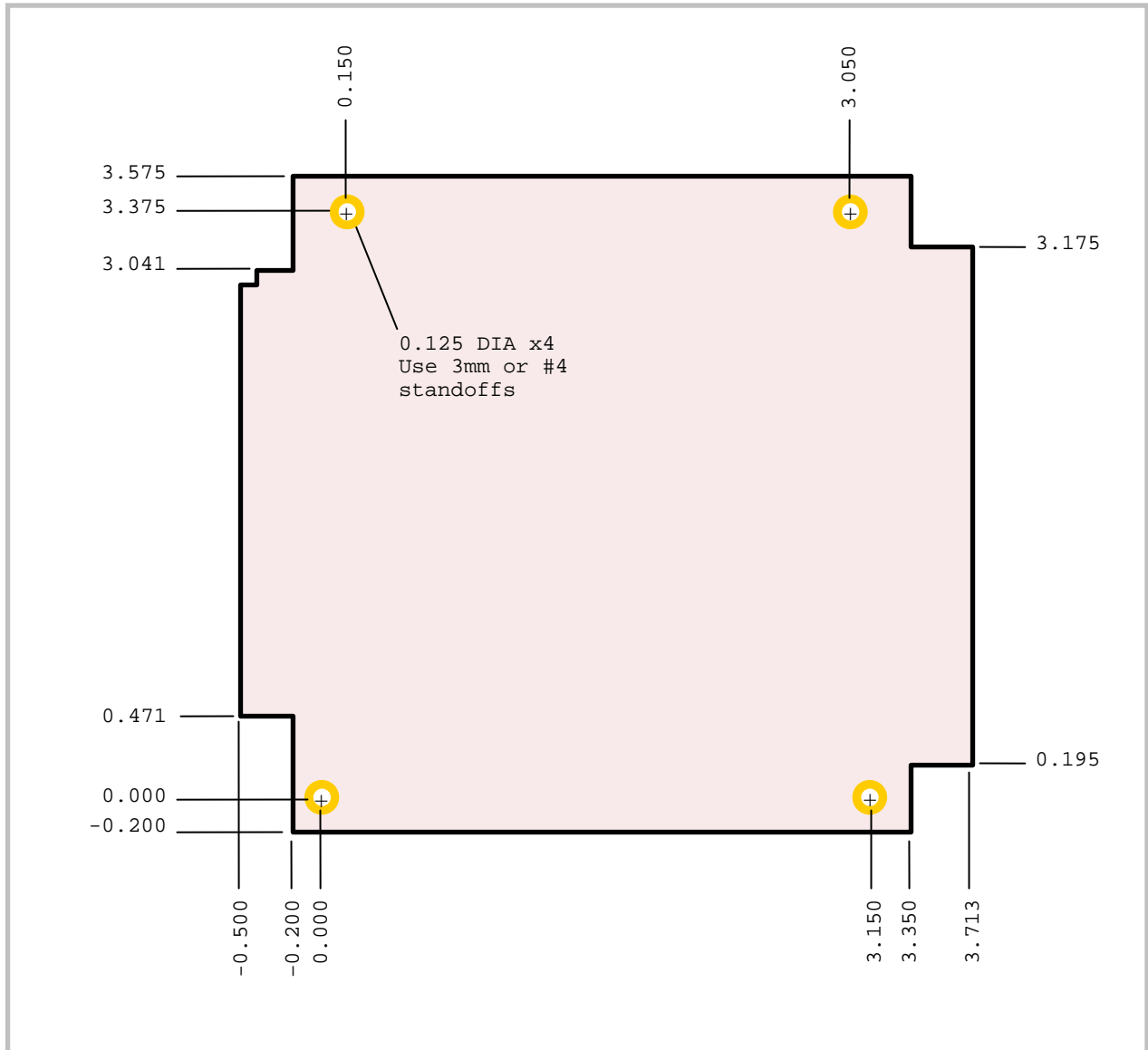

Figure 3.VL-EPMp-34 Dimensions and Mounting Holes (Top View)

(Not to scale. All dimensions in inches.)

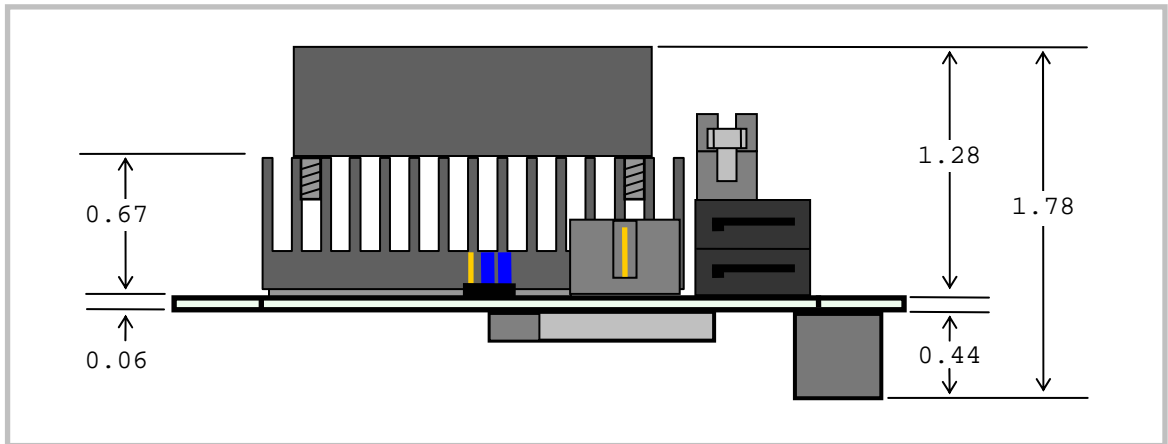

Figure 4. VL-EPMp-34 Height Dimensions (Side View)
 (Not to scale. All dimensions in inches.)

CBR-3406 DIMENSIONS

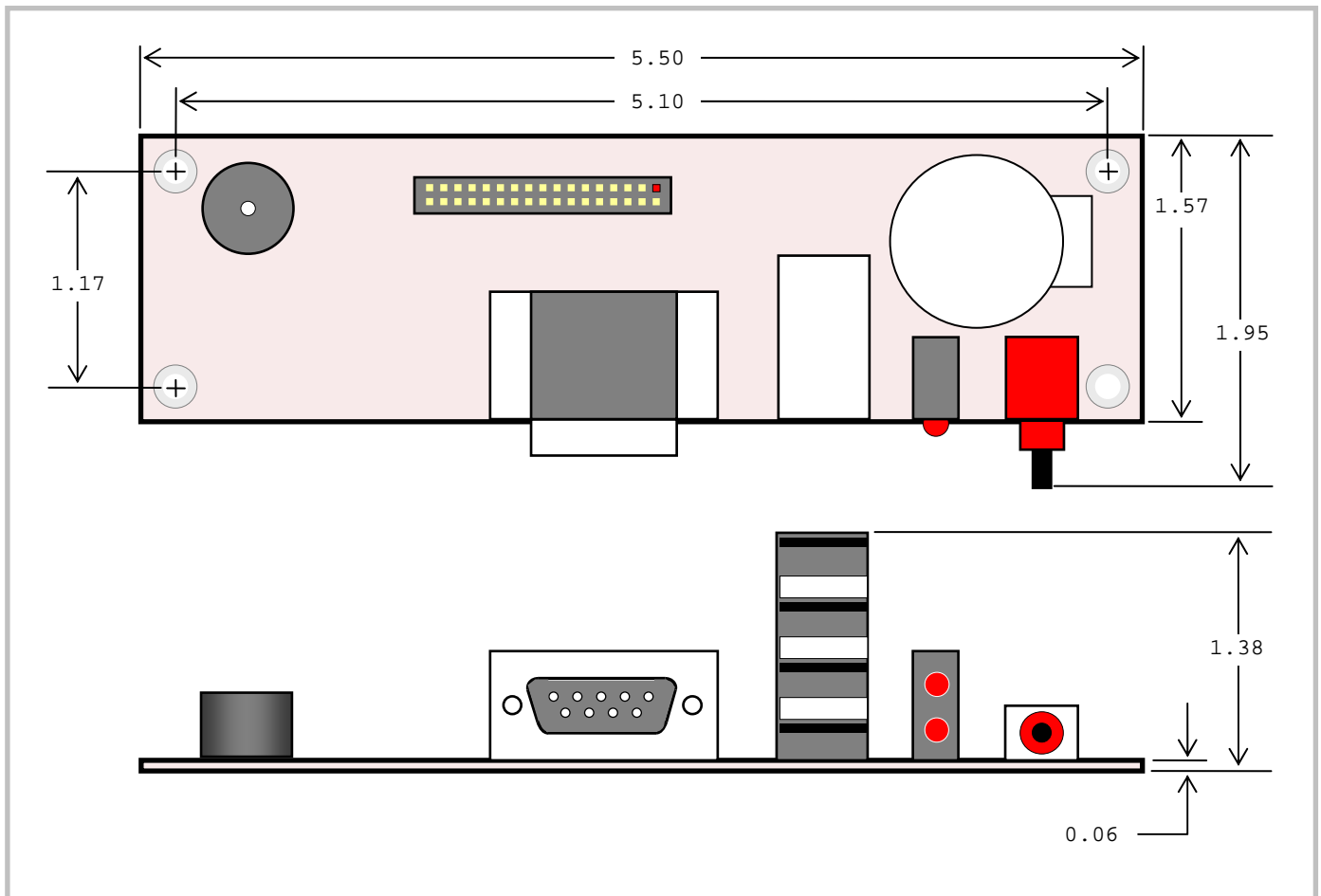

Figure 5. VL-CBR-3406 Dimensions and Mounting Holes (Top and Side Views)
 (Not to scale. All dimensions in inches.)

HARDWARE ASSEMBLY

The VL-EPMp-34 uses a pass-through PCI-104 connector so that expansion modules can be added to the bottom of the stack. There is no PC/104 (ISA) connector.

The entire assembly can sit on a table top or be secured to a base plate. When bolting the unit down, make sure to secure all four standoffs to the mounting surface to prevent circuit board flexing. Standoffs are secured to the top circuit board using four pan head screws. See page 16 for dimensional details. The 5mm x 15.25mm M3 standoffs and screws are available as part number VL-HDW-105.

An extractor tool is available (part number VL-HDW-201) to separate the PC/104 modules from the stack. Use caution when using the extractor tool not to damage any board components.

STACK ARRANGEMENT EXAMPLE

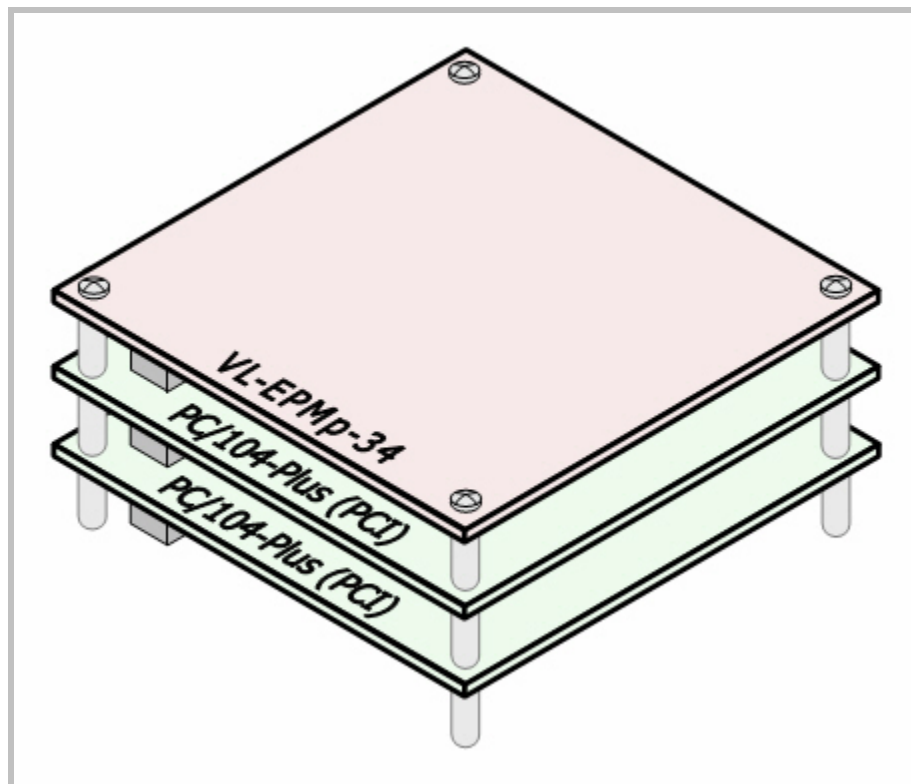

Figure 6. Stack Arrangement Example

External Connectors

VL-EPMP-34 CONNECTOR LOCATIONS – TOP

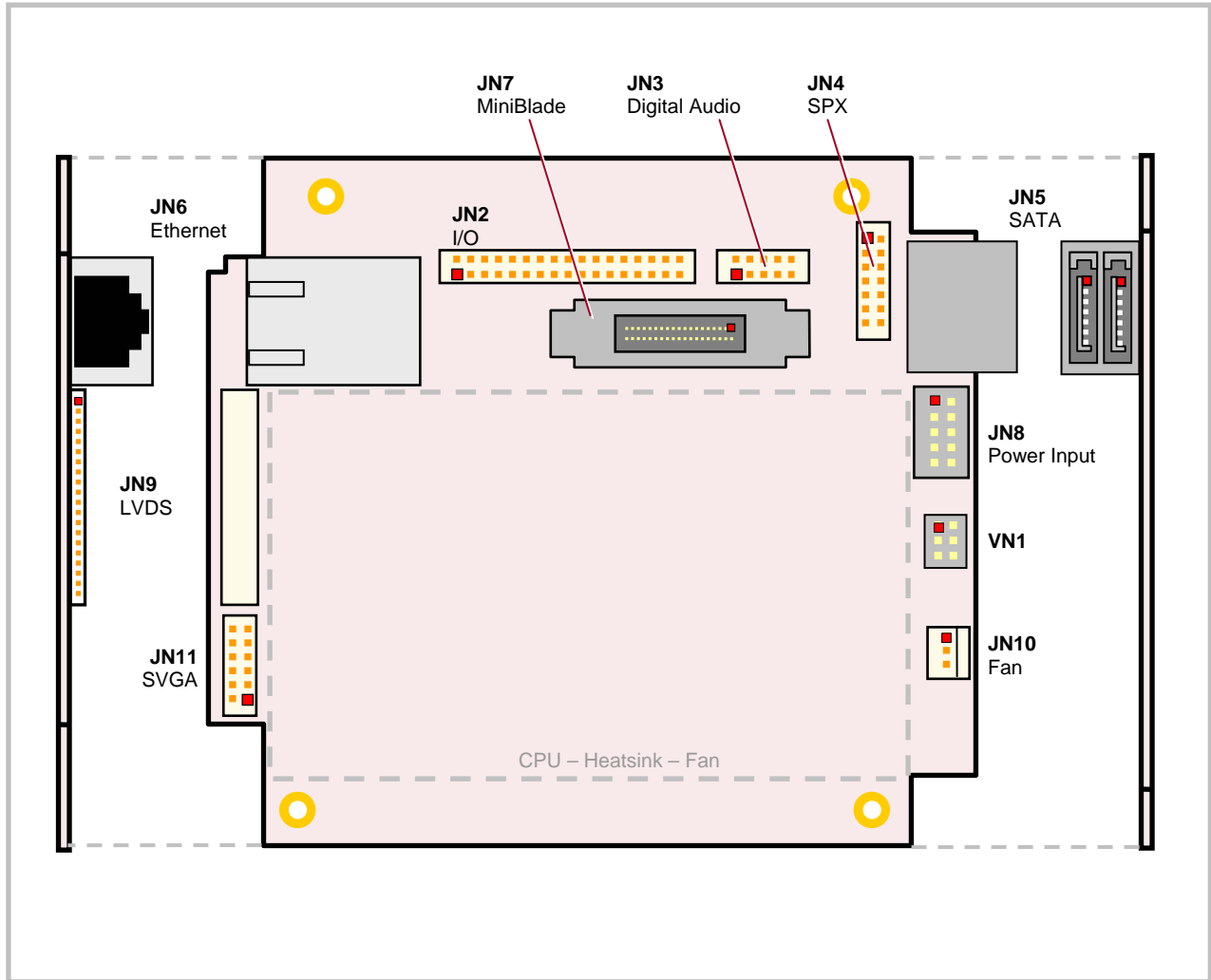

Figure 7. Connector Locations (Top View)

VL-EPMP-34 CONNECTOR LOCATIONS – BOTTOM

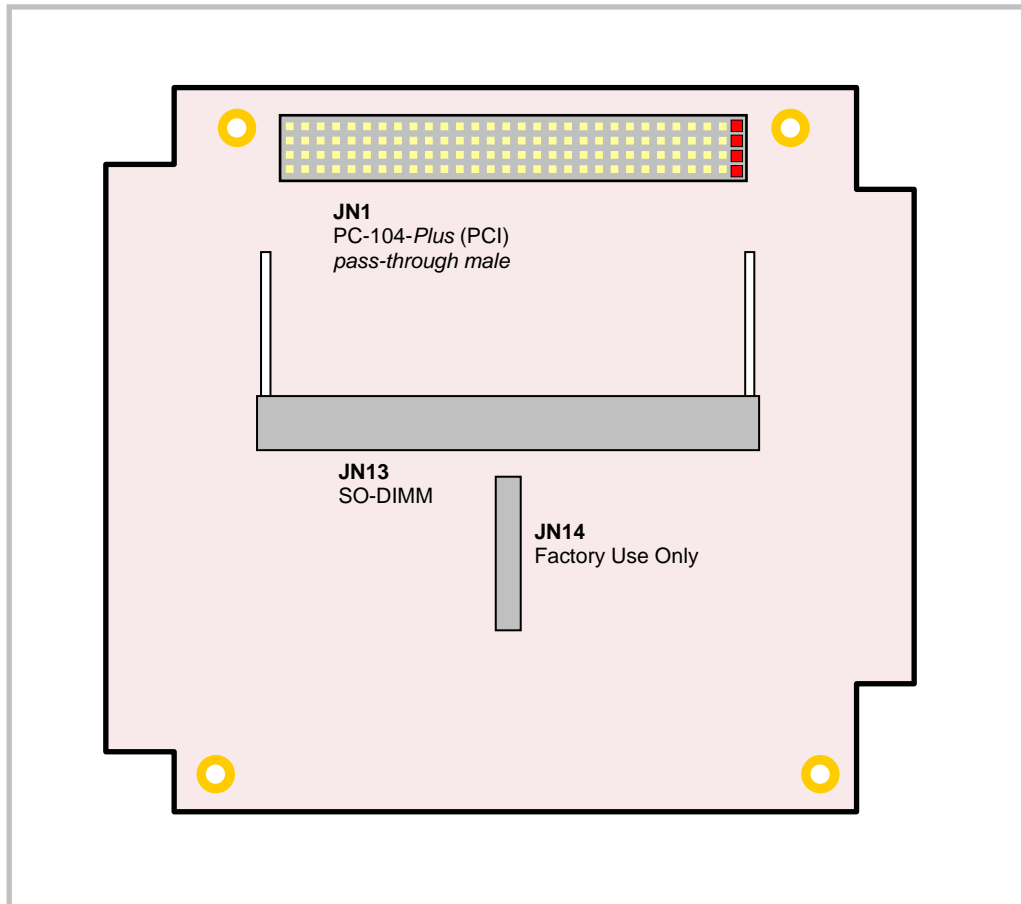

Figure 8. Connector Locations (Bottom View)

VL-EPMP-34 CONNECTOR FUNCTIONS AND INTERFACE CABLES

Table 1 provides information about the function, mating connectors, and transition cables for VL-EPMP-34 connectors. Page numbers indicate where a detailed pinout or further information is available.

Table 1: Connector Functions and Interface Cables

| Connector | Function | Mating Connector | Transition Cable | Cable Description | Pin 1 Location ¹ | | Page |
|-------------------|--|---|---|---|-----------------------------|----------|------|
| | | | | | x coord. | y coord. | |
| JN1 | PC/104-Plus (PCI) | — | — | — | 0.450 | 3.139 | 30 |
| JN2 | Serial Port, USB1-4, LEDs, Reset, Speaker, Battery | FCI 89947-334LF | VL-CBR-3406 | 34-pin latching I/O cable and breakout board | 0.862 | 2.932 | 30 |
| JN3 | Digital Audio | FCI 89361710LF | — | — | 2.385 | 2.932 | 38 |
| JN4 | SPX | FCI 89361714LF | VL-CBR-1401 or VL-CBR-1402 | 2mm 14-pin IDC, 2 or 4 SPX device cable | 3.023 | 3.119 | 39 |
| JN5 | SATA0-1 | Standard SATA | VL-CBR-0701 VL-CBR-0401 | 500mm 7-pin, straight-to-straight SATA data ATX to SATA power adapter | 3.477 | 2.960 | 33 |
| JN6 | Ethernet | RJ-45 crimp-on plug | — | — | 0.492 | 2.487 | 37 |
| JN7 | MiniBlade | USB Mini-Blade | — | — | 2.344 | 2.689 | 38 |
| JN8 | Main Power Input | Berg 69176-010 (housing) + Berg 47715-000 (pins) | VL-CBR-1008 | Interface from standard ATX power supply | 3.515 | 2.287 | 25 |
| JN9 | LVDS | Molex 51146-2000 (housing), Molex 50641-8041 (pins) | VL-CBR-2010, or VL-CBR-2011, or VL-CBR-2012 | 18-bit TFT FPD using 20-pin Hirose, or 18-bit TFT FPD using 20-pin JAE, or 24-bit TFT FPD using 20-pin Hirose | -0.195 | 2.185 | 35 |
| JN10 | Fan | Molex 22-01-3027 or Molex 22-01-2025 | Provided with assembly | — | 3.565 | 0.9700 | — |
| JN11 | Video Output | FCI 89361-712 or FCI 89947-712 | VL-CBR-1201 | 1' 12-pin 2mm latching / 15-pin HD D-Sub VGA | -0.321 | 0.605 | 34 |
| JN13 ² | Memory | DDR3 SO-DIMM | — | — | 0.473 | 1.974 | 26 |
| JN14 | Factory use only | — | — | — | — | — | — |

1. The PCB Origin is the mounting hole to the lower left, as shown in Figure 7.

2. Connector JN12 not installed.

CONNECTOR LOCATIONS – VL-CBR-3406

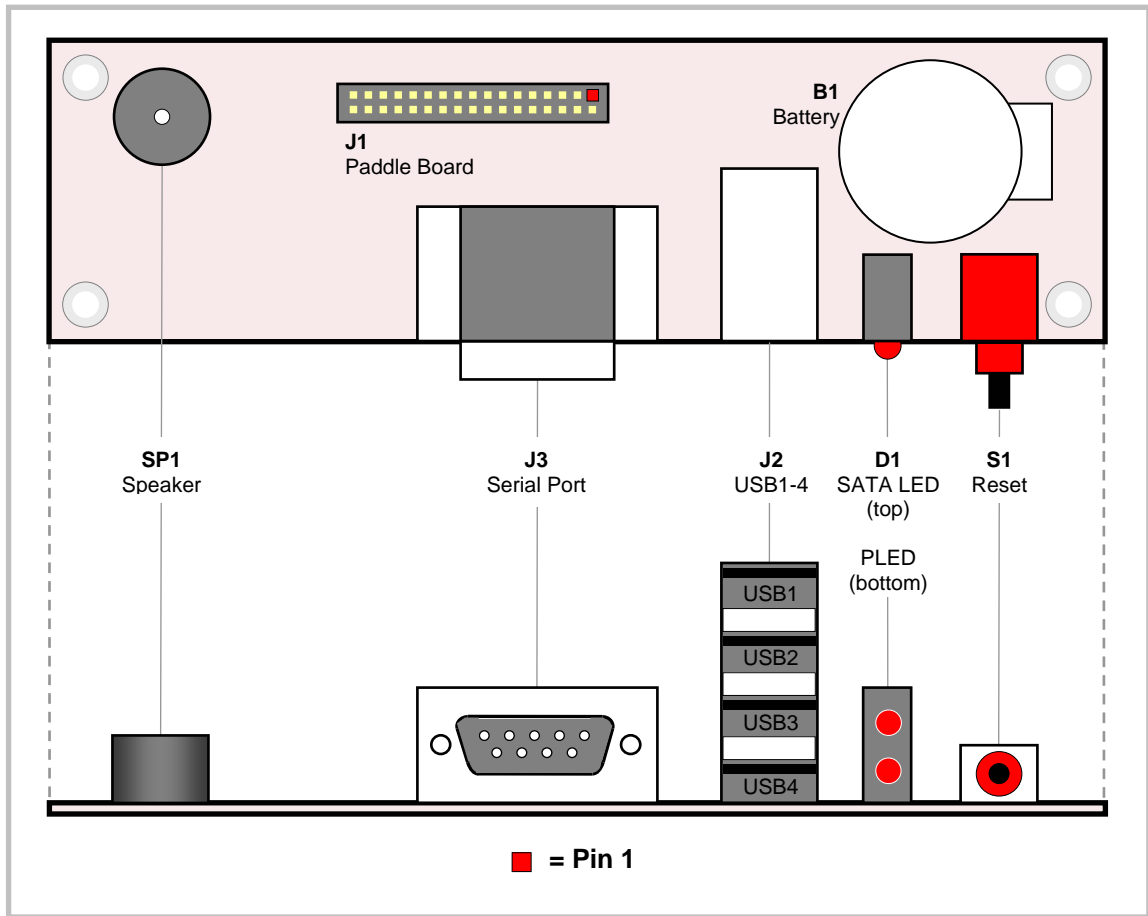

Figure 9. VL-CBR-3406 Connector Locations

CBR-3406 CONNECTOR FUNCTIONS AND MATING CONNECTORS

Table 2: VL-CBR-5010 Connector Functions and Interface Cables

| Connector | Function | PCB Connector |
|-----------|-------------------|---|
| J1 | 2mm IDC Connector | FCI 98414-F06-34ULF |
| J2 | USB 1-4 | 4 USB Type A |
| J3 | Serial Port | DB-9 male, Kycon K22X-E9P-N |
| B1 | Battery | Lithium coin battery, Panasonic BR2330A/GAE |
| D1 | SATA LED / PLED | Dual LED |
| S1 | Reset | Pushbutton |
| SP1 | Speaker | Piezo |

Jumper Blocks

JUMPERS AS-SHIPPED CONFIGURATION

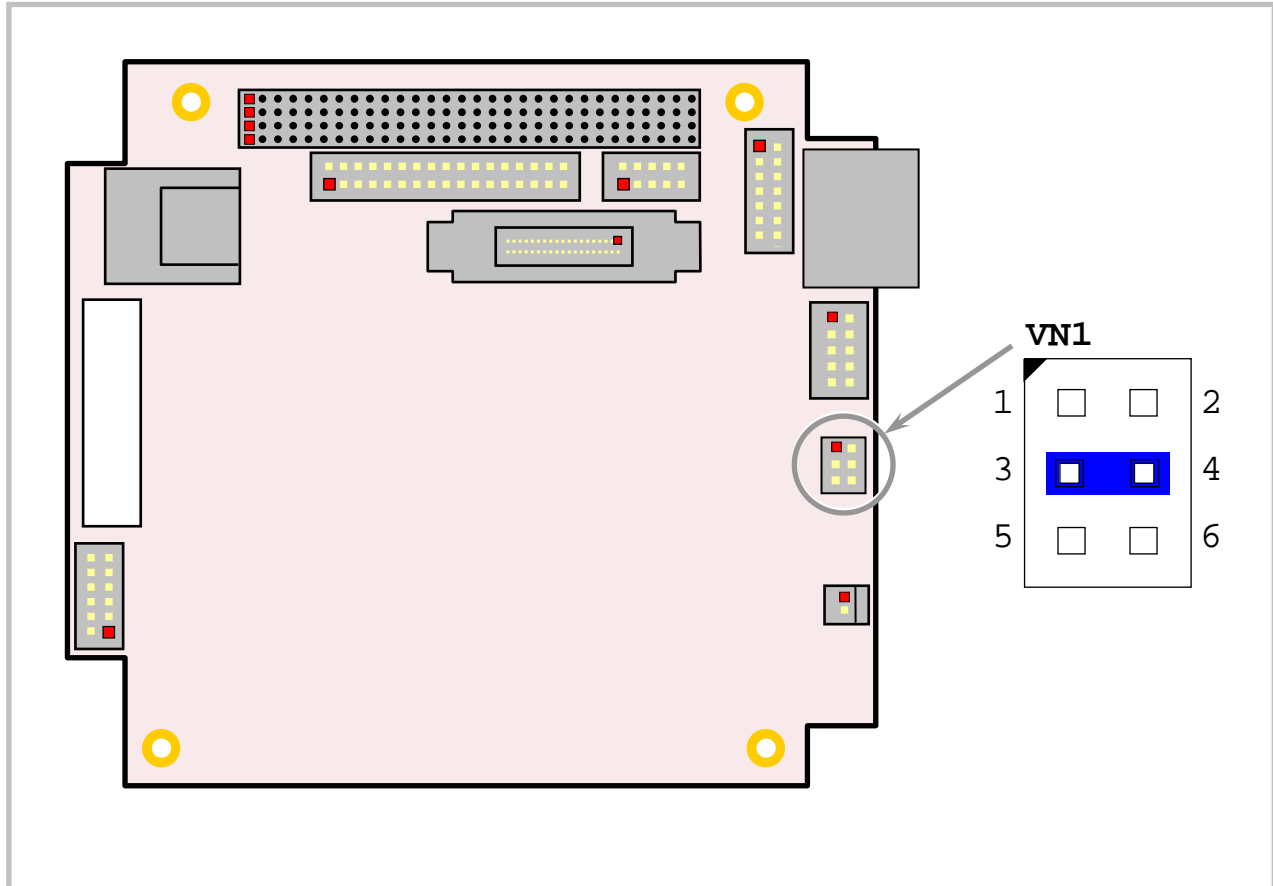

Figure 10. Jumpers As-Shipped

JUMPER SUMMARY**Table 3: Jumper Summary**

| Jumper Block | Description | As Shipped | Page |
|---------------------|---|-------------------|-------------|
| VN1[1-2] | <p>System BIOS Selector</p> <p>In – Backup system BIOS selected Out – Primary system BIOS selected</p> <p>The Primary system BIOS is field upgradeable using the BIOS upgrade utility. See http://www.VersaLogic.com/private/wildcatsupport.asp for more information.</p> | Out | 26 |
| VN1[3-4] | <p>Serial Port 5 RS-422 Termination</p> <p>In – Terminated with 120 Ohms Out – No termination</p> <p>Places terminating resistor across Serial Port 5 RS-422 RX+/RX- differential pair.</p> | In | 31 |
| VN1[5-6] | <p>CMOS RAM and Real-time Clock Erase</p> <p>In – Erase CMOS RAM and real-time clock Out – Normal operation</p> | Out | 26 |

Power Supply

POWER CONNECTORS

Main power is applied to the VL-EPMp-34 through a 10-pin polarized connector, with mating connector Berg 69176-010 (Housing) + Berg 47715-000 (Pins). See the table below for connector pinout and page 19 for location information.

Warning! To prevent severe and possibly irreparable damage to the system, it is critical that the power connectors are wired correctly. Make sure to use both +5VDC pins and all ground pins to prevent excess voltage drop. Some manufacturers include a pin-1 indicator on the crimp housing that corresponds to pin-10 of the pinout shown in Figure 11.

Table 4: Main Power Connector Pinout

| JN8 Pin | Signal Name | Description |
|---------|-------------|-------------|
| 1 | GND | Ground |
| 2 | +5VDC | Power Input |
| 3 | GND | Ground |
| 4 | +12VDC | Power Input |
| 5 | GND | Ground |
| 6 | -12VDC | Power Input |
| 7 | +3.3VDC | Power Input |
| 8 | +5VDC | Power Input |
| 9 | GND | Ground |
| 10 | +5VDC | Power Input |

Figure 11 shows the VersaLogic standard pin numbering for this type of 10-pin power connector and the corresponding mating connector.

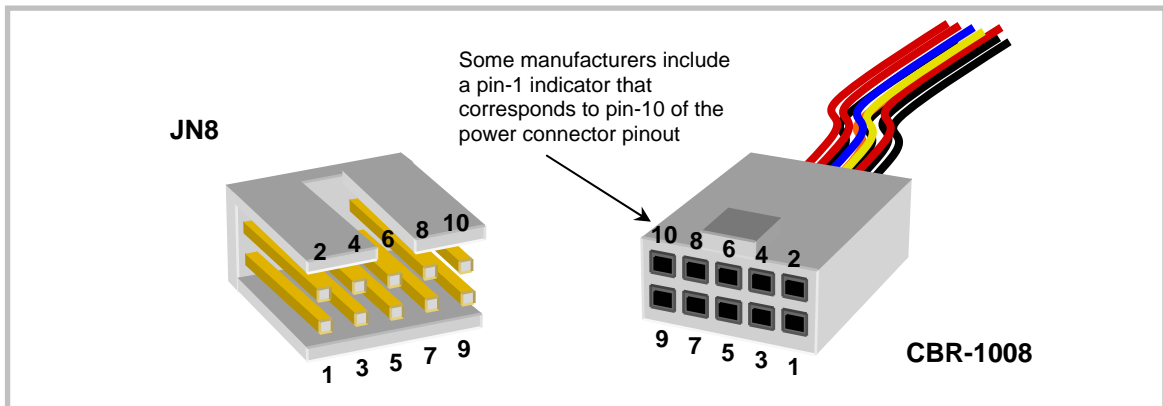

Figure 11. JN8 and VL-CBR-1008 Pin Numbering

Note: The +3.3VDC, +12VDC and -12VDC inputs are required only for expansion modules that require these voltages.

POWER REQUIREMENTS

The VL-EPMp-34 requires only +5 volts ($\pm 5\%$) for proper operation. The voltage required for the RS-232 ports is generated with an on-board DC/DC converter. A variable low-voltage supply circuit provides power to the CPU and other on-board devices.

The exact power requirement of the VL-EPMp-34 depends on several factors, including memory configuration, CPU speed, peripheral connections, type and number of expansion modules and attached devices. For example, driving long RS-232 lines at high speed can increase power demand.

The VL-EPMp-34 is equipped with a voltage sensing reset circuit. The system will reset if voltage drops below 4.63V typically (4.50V min./4.75V max.).

CPU

The Intel Core 2 Duo processor combines fast performance, using Intel's 45nm technology, with advanced power savings features. The SP9300 model used on the VL-EPMp-34 has a maximum clock rate of 2.26 GHz and a front side bus speed of 1066 MHz, and features 6 MB of L2 cache. Other features include DDR3 SDRAM support and an integrated display controller. For more CPU information see the VL-EPMp-34 support page.

System RAM

MEMORY

The VL-EPMp-34 has one DDR3 SO-DIMM socket with the following characteristics:

- Storage Capacity Up to 4GB
- Voltage 1.5V
- Type 800 MHz PC3-6400 or 1067 MHz PC3-8500

CMOS RAM

CLEARING CMOS RAM

You can install a jumper at VN1 pins 5-6 for a minimum of three seconds to erase the contents of the CMOS RAM and the real-time clock. When clearing CMOS RAM:

1. Power off the VL-EPMp-34.
2. Install a jumper on VN1[5-6] and leave it for three seconds.
3. Remove the jumper.
4. Power on the VL-EPMp-34.

Note: There is no battery on the VL-EPMp-34 mother board, only on the VL-CBR-3406 breakout board. Custom CMOS Setup values and RTC time will not be stored unless the breakout board with the battery is installed.

CMOS Setup Defaults

The VL-EPMp-34 permits users to modify CMOS Setup defaults. This allows the system to boot up with user-defined settings from cleared or corrupted CMOS RAM, battery failure or battery-less operation. All CMOS setup defaults can be changed, except the time and date. CMOS Setup defaults can be updated with the BIOS Update Utility. See the [General BIOS Information page](#) for details.

Warning! If CMOS Setup default settings make the system unbootable and prevent the user from entering CMOS Setup, the system can be recovered by switching to the backup BIOS.

DEFAULT CMOS RAM SETUP VALUES

After CMOS RAM is cleared, the system will load default CMOS RAM parameters the next time the board is powered on. The default CMOS RAM setup values will be used in order to boot the system whenever the main CMOS RAM values are blank, or when the system battery is dead or has been removed from the board.

Primary and Backup BIOS

The Primary system BIOS is field upgradeable using the BIOS upgrade utility (see the [VL-EPMp-34 Support Page](#) for more information). The Backup BIOS is available if the Primary becomes corrupted. Jumper VN[1-2] controls whether the system uses the Primary or Backup BIOS. By default the Primary BIOS is selected (jumper removed).

Real Time Clock

The VL-EPMp-34 features a year 2000-compliant, battery-backed 146818-compatible real-time clock/calendar chip. Under normal battery conditions, the clock maintains accurate timekeeping functions when the board is powered off.

Note: There is no battery on the VL-EPMp-34 mother board, only on the VL-CBR-3406 breakout board. Custom CMOS Setup values and RTC time will not be stored unless the breakout board with the battery is installed.

SETTING THE CLOCK

The CMOS Setup utility (accessed by pressing the Delete key during the early boot cycle) can be used to set the time and date of the real time clock.

Watchdog Timer

A watchdog timer circuit is included on the VL-EPMp-34 board to reset the CPU if proper software execution fails or a hardware malfunction occurs.

If the watchdog timer is enabled, software must periodically refresh the watchdog timer at a rate faster than the timer is set to expire (1000 ms minimum). Writing 5Ah to the WDHOLD register resets the watchdog timeout period. (See "Special Control Register" and "Watchdog Hold Register.")

Fan/Tachometer Monitor

The VL-EPMp-34 includes a fan/tachometer indicator circuit that can generate an interrupt if the CPU fan speed drops below 1 Hz. Bit D0 of the FANTACH register enables or disables the fan interrupt. Bit D7 indicates whether the fan is running at or above 1 Hz or below 1Hz. See "Fan/Tachometer Control Register" for more information.

FAN/TACH IRQ CODE EXAMPLE

```
#include <stdio.h>
#include <conio.h>
#include <stdlib.h>
#include <graph.h>
#include <dos.h>

//Definitions
#define TRUE          1
#define FALSE        0
#define ESC          27
#define FANREG1      0xC94
#define FANREG2      0xCA4
#define FANIRQEN     0x01
#define SLOWFAN      0x80

//Global Variables
volatile int int_hit;

//Function Prototypes
void (__interrupt __far *old_isr)(); // holds old interrupt handler
void __interrupt __far chain_isr(void);

//Main
void main()
{
    char keypressed = 0;
    int irq_count = 0;

    _clearscreen( _GCLEARSCREEN );
    _settextposition(2,1);
    printf( "FANTACH IRQ DEMO -- Stop the spinning fan to perform
test...\n" );

    _settextposition(4,1);
    printf( "Setting new ISR for IRQ 7...\n" );
    outp( 0x20, 0x20 ); //Clear any pending IRQs
```

```

old_isr = _dos_getvect( 0x0F );           //Assign function ptr to old_isr
_dos_setvect( 0x0F, chain_isr );        //Set new ISR function ptr
outp( 0x21, inp ( 0x21 ) & 0x7F );      //unmask IRQ 7 in the PIC

//Ensure slow fan status bit is cleared...
outp ( FANREG1, inp ( FANREG1 ) | SLOWFAN );
outp ( FANREG2, inp ( FANREG2 ) | SLOWFAN );

//Enable Slow/Stalled Fan Interrupt output...
outp( FANREG1, inp( FANREG1 ) | FANIRQEN );
outp( FANREG2, inp( FANREG2 ) | FANIRQEN );

_settextposition(5,1);
printf( "Listening for IRQ7...(press ESC to quit)\n" );
while (keypressed != ESC)
{
    if (kbhit())
    {
        keypressed = getch();
    }

    //Check for IRQ...
    if ( int_hit )
    {
        _settextposition(6,1);
        irq_count++;
        printf( "%d Slow/Stalled Fan IRQs Detected!\n", irq_count );
        int_hit = FALSE;
    }
}
_settextposition(7,1);
printf( "Original IRQ7 ISR restored...\n\n" );
_dos_setvect( 0x0F, old_isr );          //restore original ISR

//Turn off Slow/Stalled Fan IRQ output...
outp( FANREG1, inp( FANREG1 ) & !FANIRQEN );
outp( FANREG2, inp( FANREG2 ) & !FANIRQEN );

exit( 0 );
}

void __interrupt __far chain_isr(void)
{
    int_hit = TRUE;

    //clear slow fan status bit...(this will trigger a new IRQ,
    //if the fan is still stalled.)
    outp ( FANREG1, inp ( FANREG1 ) | SLOWFAN );
    outp ( FANREG2, inp ( FANREG2 ) | SLOWFAN );

    outp( 0x20, 0x20 );                  //EOI

    (*old_isr)();                        //call old isr
}

```

PCI-104 Expansion Bus (JN1)

PC/104-*Plus* modules can be secured directly to the bottom of the VL-EPMp-34. Make sure to correctly configure the slot position jumpers on each PC/104-*Plus* module appropriately.

The VL-EPMp-34 is compliant with revision 1.1 of the PCI-104 specification and can support four bus master capable PC/104-*Plus* modules.

The BIOS automatically allocates I/O and memory resources. However, manual PCI Interrupt routing is used.

I/O Connector (JN2)

The JN2 34-pin I/O connector incorporates the serial port, USB ports, LEDs, speaker, and the reset button. Table 5 illustrates the function of each pin and the pinout assignments to connectors on the VL-CBR-3406 breakout board.

Table 5: JN2 I/O Connector Pinout

| JN2 Pin | CBR-3406 Connector | Signal | JN2 Pin | CBR-3406 Connector | Signal |
|---------|------------------------------------|-------------|---------|--------------------------|------------------|
| 1 | Serial Port J3 | Transmit + | 18 | | USB6 Data + |
| 2 | | Transmit – | 19 | USB3 J2 Bottom | Ground |
| 3 | | Ground | 20 | | USB3 Power |
| 4 | | Receive + | 21 | | USB7 Data – |
| 5 | | Receive – | 22 | | USB7 Data + |
| 6 | | Ground | 23 | PLED | 3.3V (protected) |
| 7 | USB0 J2 Top | Ground | 24 | D1 Bottom | Programmable LED |
| 8 | | USB0 Power | 25 | IDE LED D1 Top | 3.3V (protected) |
| 9 | | USB0 Data – | 26 | | IDE LED |
| 10 | | USB0 Data + | 27 | Speaker SP1 | 3.3V (protected) |
| 11 | USB1 J2 Middle Top | Ground | 28 | | Speaker |
| 12 | | USB1 Power | 29 | 3.3V (protected) | |
| 13 | | USB1 Data – | 30 | Reserved | |
| 14 | | USB1 Data + | 31 | Battery B1 | Ground |
| 15 | USB2 J2 Middle Bottom | Ground | 32 | | Battery In |
| 16 | | USB2 Power | 33 | Reset S1 | Ground |
| 17 | | USB6 Data – | 34 | | System Reset |

All user interfaces on this connector are protected against ESD damage.

SERIAL PORT

The VL-EPMp-34 features one on-board 16550-based serial channel (Serial Port 5). Connector JN2 provides the interface to the serial port.

The serial port operates in RS-232/422/485 modes. Additional non-standard baud rates are also available (programmable in the normal baud registers) of up to 460K baud. RS-232 operation is 4-wire with only CTS and RTS handshaking.

Interrupt assignment for the serial port is handled in CMOS Setup. The port can be enabled or disabled.

This connector is protected against ESD damage.

Table 6: Serial Port Pinout

| CBR-3406 J3 Pin | RS-232 | RS-422 | RS-485 |
|----------------------------|---------------|---------------|---------------|
| 1 | NC | NC | NC |
| 2 | RXD | RxD- | RxD- |
| 3 | TXD | TxD- | TxD- |
| 4 | NC | NC | NC |
| 5 | Ground | Ground | Ground |
| 6 | NC | NC | NC |
| 7 | RTS | TxD+ | TxD+ |
| 8 | CTS | RxD+ | RxD+ |
| 9 | NC | NC | NC |

Serial Port Configuration

Jumper block VN1[3-4] controls termination of the RS-422/485 differential pairs. See the Jumper Summary on page 24 for details on termination configuration.

RS-485 Mode Line Driver Control

The TxD+/TxD- differential line driver can be turned on and off by manipulating the DTR# handshake line.

USB INTERFACE

Connector JN2 includes interfaces for four USB ports. The USB interface on the VL-EPMp-34 is UHCI (Universal Host Controller Interface) and EHCI (Enhance Host Controller Interface) compatible, which provides a common industry software/hardware interface. There are four Type A USB connectors on the VL-CBR-3406 breakout board. This connector is protected against ESD damage.

BIOS Configuration

The USB channels use a number of PCI interrupts (see "Interrupt Configuration"). CMOS Setup is used to select the IRQ line routed to each PCI interrupt line.

PROGRAMMABLE LED

Connector JN2 includes an output signal for a software controlled LED. Connect the cathode of the LED to JN2 pin 24; connect the anode to +3.3V. An on-board 200 ohm resistor limits the current. A programmable LED is provided on the VL-CBR-3406 breakout board.

To turn the LED on and off, set or clear bit D7 in I/O port CA0h. When changing the register, make sure not to alter the value of the other bits.

The following code examples show how to turn the LED on and off. Refer to page 44 for further information:

| LED On | | LED Off | |
|--------|----------|---------|----------|
| MOV | DX, CA0H | MOV | DX, CA0H |
| IN | AL, DX | IN | AL, DX |
| OR | AL, 80H | AND | AL, 7FH |
| OUT | DX, AL | OUT | DX, AL |

Note: The LED is turned on by the BIOS during system startup. This causes the light to function as a "power on" indicator if it is not otherwise controlled by user code.

This connector is protected against ESD damage.

HD LED

Connector JN2 includes an output signal for a SATA Activity LED. Connect the cathode of the LED to JN2 pin 26, and connect the anode to +3.3V. An on-board 200 ohm resistor limits the current. A SATA LED is provided on the VL-CBR-3406 board. This connector is protected against ESD damage.

INTERNAL SPEAKER

Connector JN2 includes a speaker output signal at pin 28. The VL-CBR-3406 breakout board provides a Piezo electric speaker. This connector is protected against ESD damage.

LITHIUM BATTERY

Connector JN2 includes a battery input signal at pin 32. The VL-CBR-3406 breakout board provides a 3.0V battery.

Warning! To prevent shorting, premature failure or damage to the lithium battery, do not place the board on a conductive surface such as metal, black conductive foam or the outside surface of a metalized ESD protective pouch. The lithium battery may explode if mistreated. Do not recharge, disassemble or dispose of in fire. Dispose of used batteries promptly.

Normal battery voltage should be at least 3.0V. If the voltage drops below 3.0V, contact the factory for a replacement (part number T-HB3/0-1). The life expectancy under normal use is approximately 10 years. This connector is protected against ESD damage.

PUSHBUTTON RESET

Connector JN2 includes an input for a pushbutton reset switch. Shorting JN2 pin 34 to ground causes the VL-EPMp-34 to reboot. This connector is protected against ESD damage.

SATA Ports (JN5)

The VL-EPMp-34 provides two serial ATA (SATA) ports, which communicate at a rate of up to 3.0 gigabits per second. The SATA connectors at location JN5 are standard 7-pin straight SATA friction latching connectors.

Power to SATA drives is supplied by the ATX power supply. Note that the standard SATA drive power connector is different than the common 4-pin Molex connector used on IDE drives. Most current ATX power supplies provide SATA connectors, and many SATA drives provide both types of power connectors. If the power supply you are using does not provide SATA connectors, adapters are available.

Table 7: SATA Port Pinout (JN5)

| JN5 Pin Bottom | JN5 Pin Top | Signal Name | Function |
|----------------|-------------|-------------|------------|
| 1 | 8 | GND | Ground |
| 2 | 9 | TX+ | Transmit + |
| 3 | 10 | TX- | Transmit - |
| 4 | 11 | GND | Ground |
| 5 | 12 | RX- | Receive - |
| 6 | 13 | RX+ | Receive + |
| 7 | 14 | GND | Ground |

Video Interface

An on-board video controller integrated into the chipset provides high performance video output for the VL-EPMp-34. The VL-EPMp-34 can also be operated without video attached. See “Console Redirection.”

CONFIGURATION

The VL-EPMp-34 uses a shared-memory architecture. It supports two types of video output, SVGA and LVDS Flat Panel Display.

SVGA OUTPUT CONNECTOR (JN11)

See the *Connector Location Diagram* on page 19 for connector location information. An adapter cable, part number VL-CBR-1201, is available to translate JN11 into a standard 15-pin D-Sub SVGA connector.

This connector is protected against ESD damage.

Table 8: Video Output Pinout

| JN11 Pin | Signal Name | Function | Mini DB15 Pin |
|----------|-------------|------------------|---------------|
| 1 | GND | Ground | 6 |
| 2 | CRED | Red video | 1 |
| 3 | GND | Ground | 7 |
| 4 | CGRN | Green video | 2 |
| 5 | GND | Ground | 8 |
| 6 | CBLU | Blue video | 3 |
| 7 | GND | Ground | 5 |
| 8 | CHSYNC | Horizontal Sync | 13 |
| 9 | GND | Ground | 10 |
| 10 | CVSYNC | Vertical Sync | 14 |
| 11 | DDC_CLK | DDC Clock Signal | 15 |
| 12 | DDC_DATA | DDC Data Control | 12 |

LVDS FLAT PANEL DISPLAY CONNECTOR (JN9)

The integrated LVDS Flat Panel Display in the VL-EPMp-34 is an ANSI/TIA/EIA-644-1995 specification-compliant interface. It can support up to 24 bits of RGB pixel data plus 3 bits of timing control (HSYNC/VSYNC/DE) on the 4 differential data output pairs.

The 3.3V power provided to pins 19 and 20 of JN9 is protected by a 1 Amp fuse.

See the *Connector Location Diagram* on page 19 for connector location information.

Table 9: LVDS Flat Panel Display Pinout

| JN9 Pin | Signal Name | Function |
|---------|-------------|------------------------|
| 1 | GND | Ground |
| 2 | NC | No Connection |
| 3 | LVDSA3 | Diff. Data 3 (+) |
| 4 | LVDSA3# | Diff. Data 3 (-) |
| 5 | GND | Ground |
| 6 | LVDSCLK0 | Differential Clock (+) |
| 7 | LVDSCLK0# | Differential Clock (-) |
| 8 | GND | Ground |
| 9 | LVDSA2 | Diff. Data 2 (+) |
| 10 | LVDSA2# | Diff. Data 2 (-) |
| 11 | GND | Ground |
| 12 | LVDSA1 | Diff. Data 1 (+) |
| 13 | LVDSA1# | Diff. Data 1 (-) |
| 14 | GND | Ground |
| 15 | LVDSA0 | Diff. Data 0 (+) |
| 16 | LVDSA0# | Diff. Data 0 (-) |
| 17 | GND | Ground |
| 18 | GND | Ground |
| 19 | +3.3V | Protected Power Supply |
| 20 | +3.3V | Protected Power Supply |

COMPATIBLE LVDS PANEL DISPLAYS

The following list of flat panel displays is reported to work properly with the integrated graphics video controller chip used on the VL-EPMp-34.

Table 10: Compatible Flat Panel Displays

| Manufacture | Model Number | Panel Size | Resolution | Interface | Panel Technology |
|------------------|------------------|------------|-------------------|-----------|------------------|
| eVision Displays | xxx084S01 series | 8.4" | 800 x 600 18-bit | LVDS | TFT |
| au Optronix | B084SN01 | 8.4" | 800 x 600 18-bit | LVDS | TFT |
| eVision Displays | xxx104S01 series | 10.4" | 800 x 600 18-bit | LVDS | TFT |
| au Optronix | B104SN01 | 10.4" | 800 x 600 18-bit | LVDS | TFT |
| Sharp | LQ121S1LG411 | 12.1" | 800 x 600 18-bit | LVDS | TFT |
| eVision Displays | xxx141X01 series | 14.1" | 1024 x 768 18-bit | LVDS | TFT |

CONSOLE REDIRECTION

The VL-EPMp-34 can be operated without using the on-board video output by redirecting the console to the serial communications port. CMOS Setup and some operating systems such as DOS can use this console for user interaction.

Console redirection settings are configured on the Features tab of CMOS Setup. The default setting (On Remote User Detect) causes the console not to be redirected to the serial port unless a signal (a Ctrl-C character) is detected from the terminal. Console redirection can also be set to Always or Never. Notes on console redirection:

- When console redirection is enabled, you can access CMOS Setup by typing Ctrl-C.
- The decision to redirect the console is made early in BIOS execution, and cannot be changed later.
- The redirected console uses 115200 baud, 8 data bits, 1 stop bit, no parity, and no flow control.

Null Modem

The following diagram illustrates a typical DB9 to DB9 RS-232 null modem adapter.

| System 1 | | <--> | System 2 |
|----------|-----|------|----------|
| Name | Pin | | Pin Name |
| | | | |
| TX | 3 | <--> | 2 RX |
| RX | 2 | <--> | 3 TX |
| RTS | 7 | <--> | 1 DCD |
| CTS | 8 | | |
| DSR | 6 | <--> | 4 DTR |
| DCD | 1 | <--> | 7 RTS |
| | | | 8 CTS |
| DTR | 4 | <--> | 6 DSR |

Pins 7 and 8 are shorted together on each connector. Unlisted pins have no connection.

Ethernet Interface (JN6)

The VL-EPMp-34 features an on-board Intel 82574IT gigabit Ethernet controller, which provides a standard IEEE 802.3 Ethernet interface for 1000Base-T, 100Base-TX, and 10Base-T applications.

ETHERNET CONNECTOR

A board-mounted RJ45 connector is provided to make connection with a Category 5 or 6 Ethernet cable. The 82574IT Ethernet controller auto-negotiates connection speed. This connector is protected against ESD damage.

ETHERNET STATUS LEDs

The RJ-45 connector has two built-in LEDs to provide an indication of the Ethernet status as shown in the following table.

Table 11: Ethernet Status LEDs

| LED | State | Description |
|------------------------------|--------|---|
| Green/Orange (Link Speed) | Orange | 1 Gbps speed |
| | Green | 100 Mbps speed |
| | Off | 10 Mbps speed or cable not plugged into active hub |
| Yellow (Activity) | On | Activity detected on cable (intermittent with activity) |
| | Off | No activity detected on cable |

Digital Audio (JN3)

The digital audio interface on the VL-EPMp-34 allows you to connect an external audio codec to the system. Contact [VersaLogic Customer Support](#) for available external codecs. This connector is protected against ESD damage.

Table 12: JN3 Audio Connector

| JN3 Pin | Signal Name | Function |
|---------|---------------|-------------------|
| 1 | HDA_BIT_CLK_0 | Clock |
| 2 | Ground | Ground |
| 3 | HDA_SDOOUT_0 | Line Out |
| 4 | Ground | Ground |
| 5 | HDA_SDIN_0 | Line In |
| 6 | Ground | Ground |
| 7 | HDA_SYNC_0 | Frame sync |
| 8 | V3_3 | +3.3V (protected) |
| 9 | HDA_RST_0# | Reset |
| 10 | V3_3 | +3.3V (protected) |

MiniBlade (JN7)

A vertical MiniBlade socket is provided at position JN7 for solid state storage. The MiniBlade interface on the VL-EPMp-34 supports only USB devices. The VL-F23 series of MiniBlade devices are available from VersaLogic in sizes of 1 GB, 2 GB, and 4 GB. Contact [VersaLogic Sales](#) to order.

SPX™ Expansion Bus (JN4)

Up to four serial peripheral expansion (SPX) devices can be attached to the VL-EPMp-34 at connector JN4 using the VL-CBR-1401 or VL-CBR-1402 cable. The SPX interface provides the standard serial peripheral interface (SPI) signals: SCLK, MISO, and MOSI, as well as four chip selects, SS0# to SS3#, and an interrupt input, SINT#.

The 5.0V power provided to pins 1 and 14 of JN4 is protected by a 1 Amp fuse.

Table 13: SPX Expansion Bus Pinout

| JN4 Pin | Signal Name | Function |
|---------|-------------|-------------------|
| 1 | V5_0 | +5.0V (Protected) |
| 2 | SCLK | Serial Clock |
| 3 | GND | Ground |
| 4 | MISO | Serial Data In |
| 5 | GND | Ground |
| 6 | MOSI | Serial Data Out |
| 7 | GND | Ground |
| 8 | SS0# | Chip Select 0 |
| 9 | SS1# | Chip Select 1 |
| 10 | SS2# | Chip Select 2 |
| 11 | SS3# | Chip Select 3 |
| 12 | GND | Ground |
| 13 | SINT# | Interrupt Input |
| 14 | V5_0 | +5.0V (Protected) |

SPI is, in its simplest form, a three wire serial bus. One signal is a Clock, driven only by the permanent Master device on-board. The others are Data In and Data Out with respect to the Master. The SPX implementation adds additional features, such as chip selects and an interrupt input to the Master. The Master device initiates all SPI transactions. A slave device responds when its Chip Select is asserted and it receives Clock pulses from the Master.

The SPI clock rate can be software configured to operate at speeds between 1 MHz and 8 MHz. Please note that since this clock is divided from a 33 MHz PCI clock, the actual generated frequencies are not discrete integer MHz frequencies. All four common SPI modes are supported through the use of clock polarity and clock idle state controls.

VERSALOGIC SPX EXPANSION MODULES

VersaLogic offers a number of SPX modules that provide a variety of standard functions, such as analog input, digital I/O, CANbus controller, and others. These are small boards (1.2" x 3.775") that can mount on the PC/104 stack, using standard PC/104 stand-offs, or up to two feet away from the base board. For more information, contact VersaLogic at Info@VersaLogic.com.

SPI REGISTERS

A set of control and data registers are available for SPI transactions. The following tables describe the SPI control registers (SPICONTROL and SPISTATUS) and data registers (SPIDATA3-0).

SPICONTROL (READ/WRITE) CA8h (or C98h)

| | | | | | | | |
|------|------|---------|---------|--------|-----|-----|-----|
| D7 | D6 | D5 | D4 | D3 | D2 | D1 | D0 |
| CPOL | CPHA | SPILEN1 | SPILEN0 | MAN_SS | SS2 | SS1 | SS0 |

Table 14: SPI Control Register 1 Bit Assignments

| Bit | Mnemonic | Description | | | | | | | | | | | | | | | | | | | | | | | | | | | | | | | | | | | | |
|---------|----------|--|--------------------------------|---------|--------------|--------------|---|-------|---|---------------------|--------|---|---|-------------------------------|---|---|--------|-------------------------------|---|---|---|--------------------------------|---|---|---|--------------------------------|---|---|---|----------|---|---|---|----------|---|---|---|----------|
| D7 | CPOL | SPI Clock Polarity – Sets the SCLK idle state. 0 = SCLK idles low 1 = SCLK idles high | | | | | | | | | | | | | | | | | | | | | | | | | | | | | | | | | | | | |
| D6 | CPHA | SPI Clock Phase – Sets the SCLK edge on which valid data will be read. 0 = Data read on rising edge 1 = Data read on falling edge | | | | | | | | | | | | | | | | | | | | | | | | | | | | | | | | | | | | |
| D5-D4 | SPILEN | SPI Frame Length – Sets the SPI frame length. This selection works in manual and auto slave select modes. <table border="1"> <thead> <tr> <th>SPILEN1</th> <th>SPILEN0</th> <th>Frame Length</th> </tr> </thead> <tbody> <tr> <td>0</td> <td>0</td> <td>8-bit</td> </tr> <tr> <td>0</td> <td>1</td> <td>16-bit</td> </tr> <tr> <td>1</td> <td>0</td> <td>24-bit</td> </tr> <tr> <td>1</td> <td>1</td> <td>32-bit</td> </tr> </tbody> </table> | SPILEN1 | SPILEN0 | Frame Length | 0 | 0 | 8-bit | 0 | 1 | 16-bit | 1 | 0 | 24-bit | 1 | 1 | 32-bit | | | | | | | | | | | | | | | | | | | | | |
| SPILEN1 | SPILEN0 | Frame Length | | | | | | | | | | | | | | | | | | | | | | | | | | | | | | | | | | | | |
| 0 | 0 | 8-bit | | | | | | | | | | | | | | | | | | | | | | | | | | | | | | | | | | | | |
| 0 | 1 | 16-bit | | | | | | | | | | | | | | | | | | | | | | | | | | | | | | | | | | | | |
| 1 | 0 | 24-bit | | | | | | | | | | | | | | | | | | | | | | | | | | | | | | | | | | | | |
| 1 | 1 | 32-bit | | | | | | | | | | | | | | | | | | | | | | | | | | | | | | | | | | | | |
| D3 | MAN_SS | SPI Manual Slave Select Mode – This bit determines whether the slave select lines are controlled through the user software or are automatically controlled by a write operation to SPIDATA3 (CADh). If MAN_SS = 0, then the slave select operates automatically; if MAN_SS = 1, then the slave select line is controlled manually through SPICONTROL bits SS2, SS1, and SS0. 0 = Automatic, default 1 = Manual | | | | | | | | | | | | | | | | | | | | | | | | | | | | | | | | | | | | |
| D2-D0 | SS | SPI Slave Select – These bits select which slave select will be asserted. The SSx# pin on the base board will be directly controlled by these bits when MAN_SS = 1. <table border="1"> <thead> <tr> <th>SS2</th> <th>SS1</th> <th>SS0</th> <th>Slave Select</th> </tr> </thead> <tbody> <tr> <td>0</td> <td>0</td> <td>0</td> <td>None, port disabled</td> </tr> <tr> <td>0</td> <td>0</td> <td>1</td> <td>SPX Slave Select 0, JN4 pin-8</td> </tr> <tr> <td>0</td> <td>1</td> <td>0</td> <td>SPX Slave Select 1, JN4 pin-9</td> </tr> <tr> <td>0</td> <td>1</td> <td>1</td> <td>SPX Slave Select 2, JN4 pin-10</td> </tr> <tr> <td>1</td> <td>0</td> <td>0</td> <td>SPX Slave Select 3, JN4 pin-11</td> </tr> <tr> <td>1</td> <td>0</td> <td>1</td> <td>Reserved</td> </tr> <tr> <td>1</td> <td>1</td> <td>0</td> <td>Reserved</td> </tr> <tr> <td>1</td> <td>1</td> <td>1</td> <td>Reserved</td> </tr> </tbody> </table> | SS2 | SS1 | SS0 | Slave Select | 0 | 0 | 0 | None, port disabled | 0 | 0 | 1 | SPX Slave Select 0, JN4 pin-8 | 0 | 1 | 0 | SPX Slave Select 1, JN4 pin-9 | 0 | 1 | 1 | SPX Slave Select 2, JN4 pin-10 | 1 | 0 | 0 | SPX Slave Select 3, JN4 pin-11 | 1 | 0 | 1 | Reserved | 1 | 1 | 0 | Reserved | 1 | 1 | 1 | Reserved |
| SS2 | SS1 | SS0 | Slave Select | | | | | | | | | | | | | | | | | | | | | | | | | | | | | | | | | | | |
| 0 | 0 | 0 | None, port disabled | | | | | | | | | | | | | | | | | | | | | | | | | | | | | | | | | | | |
| 0 | 0 | 1 | SPX Slave Select 0, JN4 pin-8 | | | | | | | | | | | | | | | | | | | | | | | | | | | | | | | | | | | |
| 0 | 1 | 0 | SPX Slave Select 1, JN4 pin-9 | | | | | | | | | | | | | | | | | | | | | | | | | | | | | | | | | | | |
| 0 | 1 | 1 | SPX Slave Select 2, JN4 pin-10 | | | | | | | | | | | | | | | | | | | | | | | | | | | | | | | | | | | |
| 1 | 0 | 0 | SPX Slave Select 3, JN4 pin-11 | | | | | | | | | | | | | | | | | | | | | | | | | | | | | | | | | | | |
| 1 | 0 | 1 | Reserved | | | | | | | | | | | | | | | | | | | | | | | | | | | | | | | | | | | |
| 1 | 1 | 0 | Reserved | | | | | | | | | | | | | | | | | | | | | | | | | | | | | | | | | | | |
| 1 | 1 | 1 | Reserved | | | | | | | | | | | | | | | | | | | | | | | | | | | | | | | | | | | |

SPISTATUS (READ/WRITE) CA9h (or C99h)

| D7 | D6 | D5 | D4 | D3 | D2 | D1 | D0 |
|---------|---------|---------|---------|-----------|-----------|--------|------|
| IRQSEL1 | IRQSEL0 | SPICLK1 | SPICLK0 | HW_IRQ_EN | LSBIT_1ST | HW_INT | BUSY |

Table 15: SPI Control Register 2 Bit assignments

| Bit | Mnemonic | Description | | | | | | | | | | | | | | | |
|---------|-----------|---|---------|---------|-----------|---|---|-----------|---|---|-----------|---|---|-----------|---|---|-----------|
| D7-D6 | IRQSEL | <p>IRQ Select – These bits select which IRQ will be asserted when a hardware interrupt from a connected SPI device occurs. The HW_IRQ_EN bit must be set to enable SPI IRQ functionality.</p> <table border="1"> <thead> <tr> <th>IRQSEL1</th> <th>IRQSEL0</th> <th>IRQ</th> </tr> </thead> <tbody> <tr> <td>0</td> <td>0</td> <td>IRQ3</td> </tr> <tr> <td>0</td> <td>1</td> <td>IRQ4</td> </tr> <tr> <td>1</td> <td>0</td> <td>IRQ5</td> </tr> <tr> <td>1</td> <td>1</td> <td>IRQ10</td> </tr> </tbody> </table> | IRQSEL1 | IRQSEL0 | IRQ | 0 | 0 | IRQ3 | 0 | 1 | IRQ4 | 1 | 0 | IRQ5 | 1 | 1 | IRQ10 |
| IRQSEL1 | IRQSEL0 | IRQ | | | | | | | | | | | | | | | |
| 0 | 0 | IRQ3 | | | | | | | | | | | | | | | |
| 0 | 1 | IRQ4 | | | | | | | | | | | | | | | |
| 1 | 0 | IRQ5 | | | | | | | | | | | | | | | |
| 1 | 1 | IRQ10 | | | | | | | | | | | | | | | |
| D5-D4 | SPICLK | <p>SPI SCLK Frequency – These bits set the SPI clock frequency.</p> <table border="1"> <thead> <tr> <th>SPICLK1</th> <th>SPICLK0</th> <th>Frequency</th> </tr> </thead> <tbody> <tr> <td>0</td> <td>0</td> <td>1.042 MHz</td> </tr> <tr> <td>0</td> <td>1</td> <td>2.083 MHz</td> </tr> <tr> <td>1</td> <td>0</td> <td>4.167 MHz</td> </tr> <tr> <td>1</td> <td>1</td> <td>8.333 MHz</td> </tr> </tbody> </table> | SPICLK1 | SPICLK0 | Frequency | 0 | 0 | 1.042 MHz | 0 | 1 | 2.083 MHz | 1 | 0 | 4.167 MHz | 1 | 1 | 8.333 MHz |
| SPICLK1 | SPICLK0 | Frequency | | | | | | | | | | | | | | | |
| 0 | 0 | 1.042 MHz | | | | | | | | | | | | | | | |
| 0 | 1 | 2.083 MHz | | | | | | | | | | | | | | | |
| 1 | 0 | 4.167 MHz | | | | | | | | | | | | | | | |
| 1 | 1 | 8.333 MHz | | | | | | | | | | | | | | | |
| D3 | HW_IRQ_EN | <p>Hardware IRQ Enable – Enables or disables the use of the selected IRQ (IRQSEL) by an SPI device. 0 = SPI IRQ disabled, default 1 = SPI IRQ enabled</p> <p>Note: The selected IRQ is shared with PC/104 ISA bus devices. CMOS settings must be configured for the desired ISA IRQ.</p> | | | | | | | | | | | | | | | |
| D2 | LSBIT_1ST | <p>SPI Shift Direction – Controls the SPI shift direction of the SPIDATA registers. The direction can be shifted toward the least significant bit or the most significant bit. 0 = SPIDATA data is left-shifted (MSbit first), default 1 = SPIDATA data is right-shifted (LSbit first)</p> | | | | | | | | | | | | | | | |
| D1 | HW_INT | <p>SPI Device Interrupt State – This bit is a status flag that indicates when the hardware SPX signal SINT# is asserted. 0 = Hardware interrupt on SINT# is deasserted 1 = Interrupt is present on SINT#</p> <p>This bit is read-only and is cleared when the SPI device's interrupt is cleared.</p> | | | | | | | | | | | | | | | |
| D0 | BUSY | <p>SPI Busy Flag – This bit is a status flag that indicates when an SPI transaction is underway. 0 = SPI bus idle 1 = SCLK is clocking data in and out of the SPIDATA registers</p> <p>This bit is read-only.</p> | | | | | | | | | | | | | | | |

SPIDATA0 (READ/WRITE) CAAh (or C9Ah)

| | | | | | | | |
|-------|----|----|----|----|----|----|-------|
| D7 | D6 | D5 | D4 | D3 | D2 | D1 | D0 |
| MSbit | | | | | | | LSbit |

SPIDATA1 (READ/WRITE) CABh (or C9Bh)

| | | | | | | | |
|-------|----|----|----|----|----|----|-------|
| D7 | D6 | D5 | D4 | D3 | D2 | D1 | D0 |
| MSbit | | | | | | | LSbit |

SPIDATA2 (READ/WRITE) CACH (or C9Ch)

| | | | | | | | |
|-------|----|----|----|----|----|----|-------|
| D7 | D6 | D5 | D4 | D3 | D2 | D1 | D0 |
| MSbit | | | | | | | LSbit |

SPIDATA3 (READ/WRITE) CADh (or C90h)

| | | | | | | | |
|-------|----|----|----|----|----|----|-------|
| D7 | D6 | D5 | D4 | D3 | D2 | D1 | D0 |
| MSbit | | | | | | | LSbit |

SPIDATA3 contains the most significant byte (MSB) of the SPI data word. A write to this register will initiate the SPI clock and, if the MAN_SS bit = 0, will also assert a slave select to begin an SPI bus transaction. Increasing frame sizes from 8-bit use the lowest address for the least significant byte of the SPI data word; for example, the LSB of a 24-bit frame would be SPIDATA1. Data is sent according to the LSBIT_1ST setting. When LSBIT_1ST = 0, the MSbit of SPIDATA3 is sent first, and received data will be shifted into the LSbit of the selected frame size set in the SPILEN field. When LSBIT_1ST = 1, the LSbit of the selected frame size is sent first, and the received data will be shifted into the MSbit of SPIDATA3.

Data returning from the SPI target will normally have its most significant data in the SPIDATA3 register. An exception will occur when LSBIT_1ST = 1 to indicate a right-shift transaction. In this case the most significant byte of an 8-bit transaction will be located in SPIDATA0, a 16-bit transaction's most significant byte will be located in SPIDATA1, and a 24-bit transaction's most significant byte will be located in SPIDATA2.

Interrupt Configuration

The VL-EPMp-34 has the standard complement of PC type interrupts. Up to six IRQ lines can be allocated as needed to PCI devices. There are no interrupt configuration jumpers. All configuration is handled through CMOS Setup.

Table 16: VL-EPMp-34 IRQ Settings

● = default setting ○ = allowed setting

| Source | IRQ | | | | | | | | | | | | | | | |
|----------------|-----|---|---|---|---|---|---|---|---|---|----|----|----|----|----|----|
| | 0 | 1 | 2 | 3 | 4 | 5 | 6 | 7 | 8 | 9 | 10 | 11 | 12 | 13 | 14 | 15 |
| Timer 0 | ● | | | | | | | | | | | | | | | |
| Keyboard | | ● | | | | | | | | | | | | | | |
| Slave PIC | | | ● | | | | | | | | | | | | | |
| Serial Port 5 | | | | ○ | ● | ○ | | ○ | | | | | | | | |
| Floppy | | | | | | | ● | | | | | | | | | |
| RTC | | | | | | | | | ● | | | | | | | |
| Mouse | | | | | | | | | | | | | ● | | | |
| Math Chip | | | | | | | | | | | | | | ● | | |
| Primary IDE | | | | | | | | | | | | | | | ● | |
| Secondary IDE | | | | | | | | | | | | | | | | ● |
| SPX | | | | ○ | ○ | ○ | | | | | ○ | | | | | |
| Fan Tachometer | | | | | | | | ○ | | | | | | | | |
| PCI INTA# | | | | | | ○ | | | | ○ | ○ | ● | | | | |
| PCI INTB# | | | | | | ○ | | | | ○ | ○ | ● | | | | |
| PCI INTC# | | | | | | ○ | | | | ○ | ○ | ● | | | | |
| PCI INTD# | | | | | | ○ | | | | ● | ○ | ○ | | | | |
| PCI INTE# | | | | | | ○ | | | | ● | ○ | ○ | | | | |
| PCI INTF# | | | | | | ○ | | | | ● | ○ | ○ | | | | |

Table 17: PCI Interrupt Settings

● = default setting ○ = allowed setting

| Source | PCI Interrupt | | | | | |
|------------------|---------------|-------|-------|-------|-------|-------|
| | INTA# | INTB# | INTC# | INTD# | INTE# | INTF# |
| 82574IT Ethernet | ● | | | | | |
| Audio | ● | | | | | |
| SATA | | ● | | | | |
| USB EHCI 1 | | | | | ● | |
| USB EHCI 2 | | | ● | | | |
| USB UHCI 1 | | | | | ● | |
| USB UHCI 2 | | | | | | ● |
| USB UHCI 3 | | | ● | | | |
| USB UHCI 4 | ● | | | | | |
| USB UHCI 5 | | ● | | | | |
| USB UHCI 6 | | | ● | | | |
| Video | ● | | | | | |



Product Code Register

PRODCODE (Read/Write) CA0h (or C90h)

| | | | | | | | |
|------|-----|-----|-----|-----|-----|-----|-----|
| D7 | D6 | D5 | D4 | D3 | D2 | D1 | D0 |
| PLED | PC6 | PC5 | PC4 | PC3 | PC2 | PC1 | PC0 |

Table 18: Product Code Register Bit Assignments

| Bit | Mnemonic | Description | | | | | | | | | | | | | | | | |
|------------|------------|---|------------|------------|------------|------------|-----------------------------|------------|------------|---------------------|---|---|---|---|---|---|---|-----------------------------|
| D7 | PLED | Light Emitting Diode — Controls the programmable LED on connector JN2. 0 = Turns LED on 1 = Turns LED off | | | | | | | | | | | | | | | | |
| D6-D0 | PC | Product Code — These bits are hard-coded to represent the product type. The VL-EPMp-34 always reads as 0000001. Other codes are reserved for future products. <table border="0" style="margin-left: 20px;"> <tr> <td>PC6</td> <td>PC5</td> <td>PC4</td> <td>PC3</td> <td>PC2</td> <td>PC1</td> <td>PC0</td> <td>Product Code</td> </tr> <tr> <td>0</td> <td>0</td> <td>0</td> <td>0</td> <td>0</td> <td>0</td> <td>1</td> <td>VL-EPMp-34 and VL-EPM-35</td> </tr> </table> <p>These bits are read-only.</p> | PC6 | PC5 | PC4 | PC3 | PC2 | PC1 | PC0 | Product Code | 0 | 0 | 0 | 0 | 0 | 0 | 1 | VL-EPMp-34 and VL-EPM-35 |
| PC6 | PC5 | PC4 | PC3 | PC2 | PC1 | PC0 | Product Code | | | | | | | | | | | |
| 0 | 0 | 0 | 0 | 0 | 0 | 1 | VL-EPMp-34 and VL-EPM-35 | | | | | | | | | | | |

Revision Level Register

REVLEV (Read Only) CA1h (or C91h)

| | | | | | | | |
|-----|-----|-----|-----|-----|-----|------|------|
| D7 | D6 | D5 | D4 | D3 | D2 | D1 | D0 |
| RL4 | RL3 | RL2 | RL1 | RL0 | EXT | CUST | BETA |

Table 19: Revision Level Register Bit Assignments

| Bit | Mnemonic | Description |
|-------|----------|---|
| D7-D3 | RL | FPGA Revision Level — These bits are hard-coded to represent the FPGA revision. Contact VersaLogic Support for further information. These bits are read-only. |
| D2 | EXT | Extended Temperature — Indicates operating temperature range. 0 = Standard temperature range 1 = Extended temperature range This bit is read-only. |
| D1 | CUSTOM | Custom Flag — Indicates whether this is a custom FPGA. 0 = Standard 1 = Custom This bit is read-only. |
| D0 | REV | Beta Flag — Indicates whether this is a Beta product. 0 = Standard 1 = Beta This bit is read-only. |

Special Control Register

SCR (Read/Write) CA2h (or C92h)

| D7 | D6 | D5 | D4 | D3 | D2 | D1 | D0 |
|----------|---------|----------|-------|-------|-----------|----------|----------|
| BIOS_JMP | BIOS_OR | BIOS_SEL | CMOD1 | CMOD0 | WDOG_STAT | WDOG_RST | Reserved |

Table 20: Special Control Register Bit Assignments

| Bit | Mnemonic | Description | | | | | | | | | | | | | | | |
|-------|-----------|---|-------|-------|--------------------|---|---|--------|---|---|--------|---|---|--------|---|---|----------|
| D7 | BIOS_JMP | System BIOS Selector Jumper Status — Indicates the status of the system BIOS selector jumper at VN1[1-2]. 0 = Jumper installed – backup system BIOS selected 1 = No jumper installed – primary system BIOS selected This bit is read-only. | | | | | | | | | | | | | | | |
| D6 | BIOS_OR | BIOS Jumper Override — Overrides the system BIOS selector jumper and selects the BIOS with BIOS_SEL. 0 = No BIOS override 1 = BIOS override | | | | | | | | | | | | | | | |
| D5 | BIOS_SEL | BIOS Select — Selects the system BIOS when BIOS_OR is set. 0 = Backup BIOS selected 1 = Primary BIOS selected | | | | | | | | | | | | | | | |
| D4-D3 | CMOD | Serial Port 5 Mode — Sets the operation mode of Serial Port 5. <table border="1"> <thead> <tr> <th>CMOD1</th> <th>CMOD0</th> <th>Serial Port 5 Mode</th> </tr> </thead> <tbody> <tr> <td>0</td> <td>0</td> <td>RS-232</td> </tr> <tr> <td>0</td> <td>1</td> <td>RS-422</td> </tr> <tr> <td>1</td> <td>0</td> <td>RS-485</td> </tr> <tr> <td>1</td> <td>1</td> <td>Disabled</td> </tr> </tbody> </table> | CMOD1 | CMOD0 | Serial Port 5 Mode | 0 | 0 | RS-232 | 0 | 1 | RS-422 | 1 | 0 | RS-485 | 1 | 1 | Disabled |
| CMOD1 | CMOD0 | Serial Port 5 Mode | | | | | | | | | | | | | | | |
| 0 | 0 | RS-232 | | | | | | | | | | | | | | | |
| 0 | 1 | RS-422 | | | | | | | | | | | | | | | |
| 1 | 0 | RS-485 | | | | | | | | | | | | | | | |
| 1 | 1 | Disabled | | | | | | | | | | | | | | | |
| D2 | WDOG_STAT | Watchdog Status — Indicates if the watchdog timer has expired. 0 = Timer has not expired. 1 = Timer has expired. This bit is read-only. | | | | | | | | | | | | | | | |
| D1 | WDOG_RST | Watchdog Reset Enable — Enables and disables the watchdog timer reset circuit. 0 = Disables 1 = Enables | | | | | | | | | | | | | | | |
| D0 | Reserved | This bit has no function. | | | | | | | | | | | | | | | |

Watchdog Hold Register

WDHOLD (Write Only) CA3h (or C93h)

| D7 | D6 | D5 | D4 | D3 | D2 | D1 | D0 |
|----|----|----|----|----|----|----|----|
| 0 | 1 | 0 | 1 | 1 | 0 | 1 | 0 |

If the watchdog timer is enabled, software must periodically refresh the watchdog timer at a rate faster than the timer is set to expire (1000 ms minimum). Writing 5Ah to WDHOLD resets the watchdog timeout period.

Fan/Tachometer Control Register

FANTACH (Read/Write) CA4h (or C94h)

| D7 | D6 | D5 | D4 | D3 | D2 | D1 | D0 |
|---------|----------|----------|----------|----------|----------|----------|--------|
| SLOWFAN | Reserved | Reserved | Reserved | Reserved | Reserved | Reserved | FANINT |

Table 21: Fan/Tachometer Control Register Bit Assignments

| Bit | Mnemonic | Description |
|-------|----------|--|
| D7 | SLOWFAN | Slow Fan Speed Indicator – Indicates whether the fan is running below 1 Hz. 0 = Fan is running at or above 1 Hz. 1 = Fan is running below 1 Hz. This bit is read-only. |
| D6-D1 | Reserved | These bits have no function. |
| D0 | FANINT | Fan Interrupt Enable — Enables or disables fan interrupt. 0 = Disables fan interrupt 1 = Enables fan interrupt – IRQ7 |

Appendix A – References



CPU

Intel Core 2 Duo

[Intel Core 2 Duo Datasheet](#)

Chipset

Intel GS45

[Intel GS45 Datasheet](#)

Intel ICH9

[Intel ICH9 Datasheet](#)

Ethernet Controller

Intel 82574IT Ethernet Controller

[Intel 82574IT Datasheet](#)

Super I/O Chip

SMSC LPC47N217

[LPCC47N217 Datasheet](#)

PCI-104 Interface

[PCI-104 Specification](#)

General PC Documentation

The Programmer's PC Sourcebook

[Amazon.com](#)

General PC Documentation

The Undocumented PC

[Amazon.com](#)